

Your technology partner for cost-effective machining

CHUCKS FOR MQL MACHINING





CHUCKS FOR MQL

Introduction

Perfect MQL technology	4
------------------------	---

Selection system

Hydraulic chucks HydroChuck for MQL	6
Shrink chucks ThermoChuck for MQL	7



1-channel system, automatic tool change



Hydraulic chucks HydroChuck with axial length adjustment	10
--	----



Shrink chucks ThermoChuck	13
---------------------------	----



1-channel system, manual tool change



Hydraulic chucks HydroChuck with axial length adjustment	16
--	----



Shrink chucks ThermoChuck	19
---------------------------	----



2-channel system, automatic tool change



Selection of chucks MQL 2-channel system	24
--	----

Hydraulic chucks HydroChuck with axial length adjustment	34
--	----



Shrink chucks ThermoChuck	42
---------------------------	----

PERFECT MQL TECHNOLOGY

To successfully introduce an MQL process, there are a number of issues that need to be taken into account, from the type of supply via the machine and the sequence of the work steps, to the usage of the correct components such as clamps and tools. A key initial task is to ensure that the air-oil mixture (aerosol) is passed smoothly through the machine spindle to the outlet at the cutting edge. For this purpose in principle two systems, the 1-channel or 2-channel system, are available.

The difference between the systems is the point at which the air-oil mixture (aerosol) is formed. On the 1-channel system the aerosol is pre-mixed already outside the spindle, while with the 2-channel version mixing only takes place directly at the inlet to the tool. The related transfer systems in the clamping tools are selected depending on the type of supply. In the next step tools suitable for MQL are designed that are specifically adapted to machining using minimum quantity lubrication, from the coolant supply to the design of the exits and chip flutes. If the work steps for the machining process are designed to suit MQL, there is no longer anything in the way of the cost reduction.

The design of all components in the machining process to suit MQL is crucial for ensuring the process results in a cost reduction. Support from an experienced technology partner is useful if the necessary in-house resources are not available. Along with years of experience in process design, MAPAL offers support in relation to all components in the MQL process chain. A complete service package for the introduction of the technology is also available.

Process design

ADVANTAGES

- High energy efficiency:
no systems for transporting the cooling lubricant with high-pressure pumps
- Resource conservation and protection of the environment:
no water consumption and no cooling lubricant disposal
- Complete process support:
system selection to training of the machine operator
- Longer tool lives: due to lower thermal load and ideal lubrication effect
- Reliable, broad tool range:
specially developed and tested standard and custom tools
- Comprehensive clamping tool programme



As the specialist for the implementation of MQL processes, along with its complete product portfolio MAPAL offers its customers support during all phases of an MQL project.

Even right at the start of a project, the tool experts help identify crucial features for successful MQL machining and take them into account as appropriate in the machining process.

During the subsequent planning and implementation phase, all components are perfectly matched to each other: a suitable clamping system, the chuck, the MQL connections and the tools.

Services



The comprehensive MAPAL service is rounded off by support during commissioning and series production. MAPAL also offers training courses on minimum quantity lubrication and can undertake machining trials.



Continuous further development

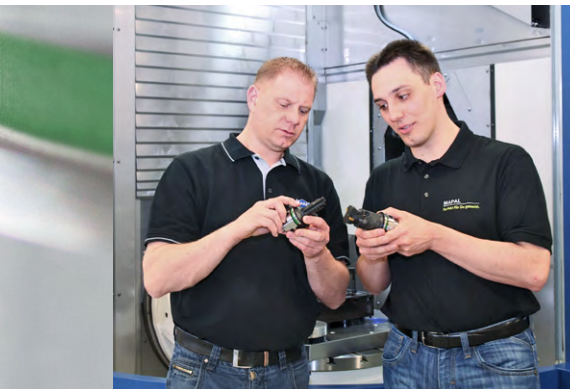

Along with the already proven solutions for MQL processes, there is also major potential for the further development and optimisation of this technology. Development engineers and designers jointly prepare suitable solutions for productive, economical MQL manufacturing. Customer workpieces can be completely machined on modern machinery with all the possible options for MQL supply.

The result is that new processes can be installed at the customer within a short time with the highest process reliability.

Dependable product quality

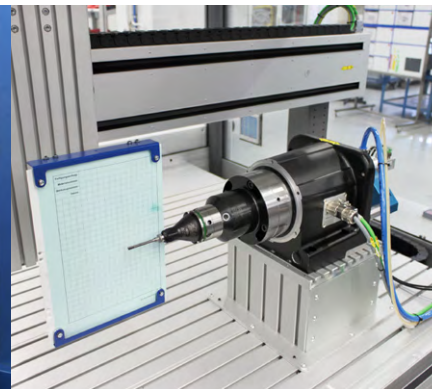

Along with an optimal process, the right tools are a prerequisite for reliable machining. MAPAL offers all its tool systems familiar from wet machining also for minimum quantity lubrication.

High performance is ensured by appropriate design guidelines that safeguard the most important characteristics of an MQL tool. These characteristics include the supply of the cutting and guide elements with the MQL medium by means of a suitable cooling channels and MQL connections, as well as ensuring chips are removed.

The consistently high quality of the MAPAL MQL tools is guaranteed by special manufacturing processes as well as a subsequent MQL spray test on the "MAPAL UNITEST MQL" tester specially developed in-house for this purpose. Only after comprehensive quality checks are the tools approved for usage.

Broad standard programme of MQL clamping tools



MAPAL offers a wide programme of tools for MQL over the entire product range. An important role for a stable MQL process is played by the related chuck so that the lubricating medium is reliably transported to the cutting edge.

MAPAL offers clamping tools for the 1-channel system and also for the 2-channel system. From shrink chucks of short and long design, through hydraulic chucks with axial or radial length adjustment, to the HighTorque Chuck (HTC). The advantages of the HTC are above all extremely high torque transmission for high-power milling and extremely good thermal stability. This aspect is particularly important, as during MQL machining relatively high temperatures reach the chuck via the tool shank.

Selection system hydraulic chucks

HydroChuck for MQL

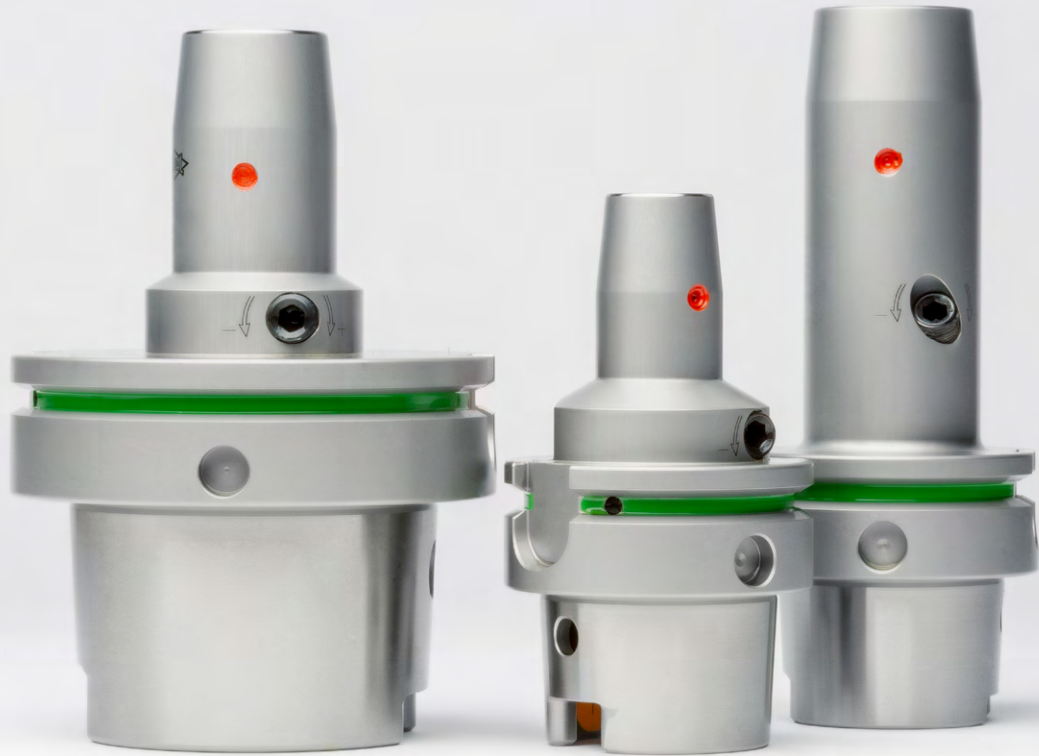

Hydraulic chucks HydroChuck	1-channel system	Automatic tool change Preferred series in stock	HSK-A063 Short, L ₁ =120 HSK-A100 Short	Axial	Page 10
		Automatic tool change Further versions on request	HSK-A040 Short, L ₁ =120, L ₁ =160 HSK-A050 Short, L ₁ =120, L ₁ =160 HSK-A063 L ₁ =160, L ₁ =200 HSK-A080 Short HSK-A100 L ₁ =120, L ₁ =160, L ₁ =200	Axial	Page 11
		Manual tool change On request	HSK-A040 Short, L ₁ =120 HSK-A050 Short, L ₁ =120 HSK-A063 L ₁ =120, L ₁ =160, L ₁ =200 HSK-A100 L ₁ =120, L ₁ =160, L ₁ =200	Axial	Page 16
	2-channel system*	Automatic tool change Preferred series in stock	HSK-A063 Short, L ₁ =120 HSK-A100 Short	Axial	Page 34
		Automatic tool change Further versions on request	HSK-A040 Short, L ₁ =120, L ₁ =160 HSK-A050 Short, L ₁ =120, L ₁ =160 HSK-A063 L ₁ =160, L ₁ =200 HSK-A100 L ₁ =120, L ₁ =160, L ₁ =200	Axial	Page 36
		Manual tool change On request			

* Due to the need to maintain the MQL ratio, up to three different coolant supply units with the related length adjustment screw can be selected for one shank diameter. For more detailed information and a detailed selection system, see from page 24.

Selection system shrink chucks ThermoChuck for MQL

- 1 1-channel system MQL for automatic tool change
- 2 1-channel system MQL for manual tool change
- 3 2-channel system MQL for automatic tool change

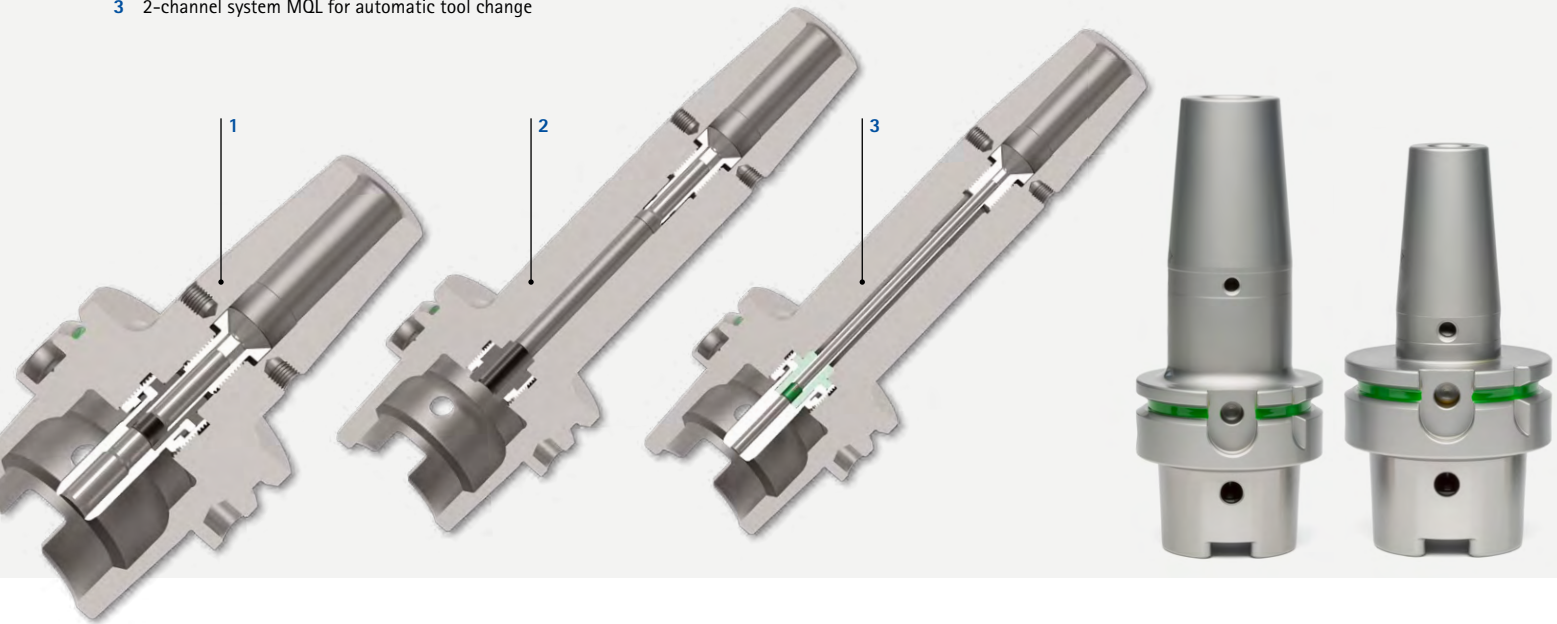

Shrink chucks ThermoChuck	1-channel system	Automatic tool change Preferred series in stock	HSK-A063 Short, L ₁ =120 HSK-A100 Short	Axial	Page 13
		Automatic tool change Further versions on request	HSK-A040 Short, L ₁ =120, L ₁ =160 HSK-A050 Short, L ₁ =120, L ₁ =160 HSK-A063 L ₁ =160, L ₁ =200 HSK-A100 L ₁ =120, L ₁ =160, L ₁ =200	Axial	Page 14
		Manual tool change On request	HSK-A040 Short HSK-A050 Short HSK-A063 Short, L ₁ =120, L ₁ =160, L ₁ =200 HSK-A080 Short HSK-A100 Short, L ₁ =120, L ₁ =160, L ₁ =200	Axial	Page 19
	2-channel system*	Automatic tool change Preferred series in stock	HSK-A063 Short, L ₁ =120 HSK-A100 Short	Axial	Page 42
		Automatic tool change Further versions on request	HSK-A040 Short, L ₁ =120, L ₁ =160 HSK-A050 Short HSK-A063 L ₁ =160, L ₁ =200 HSK-A080 Short HSK-A100 L ₁ =120, L ₁ =160, L ₁ =200	Axial	Page 44
		Manual tool change On request			

* Due to the need to maintain the MQL ratio, up to three different coolant supply units with the related length adjustment screw can be selected for one shank diameter. For more detailed information and a detailed selection system, see from page 24.

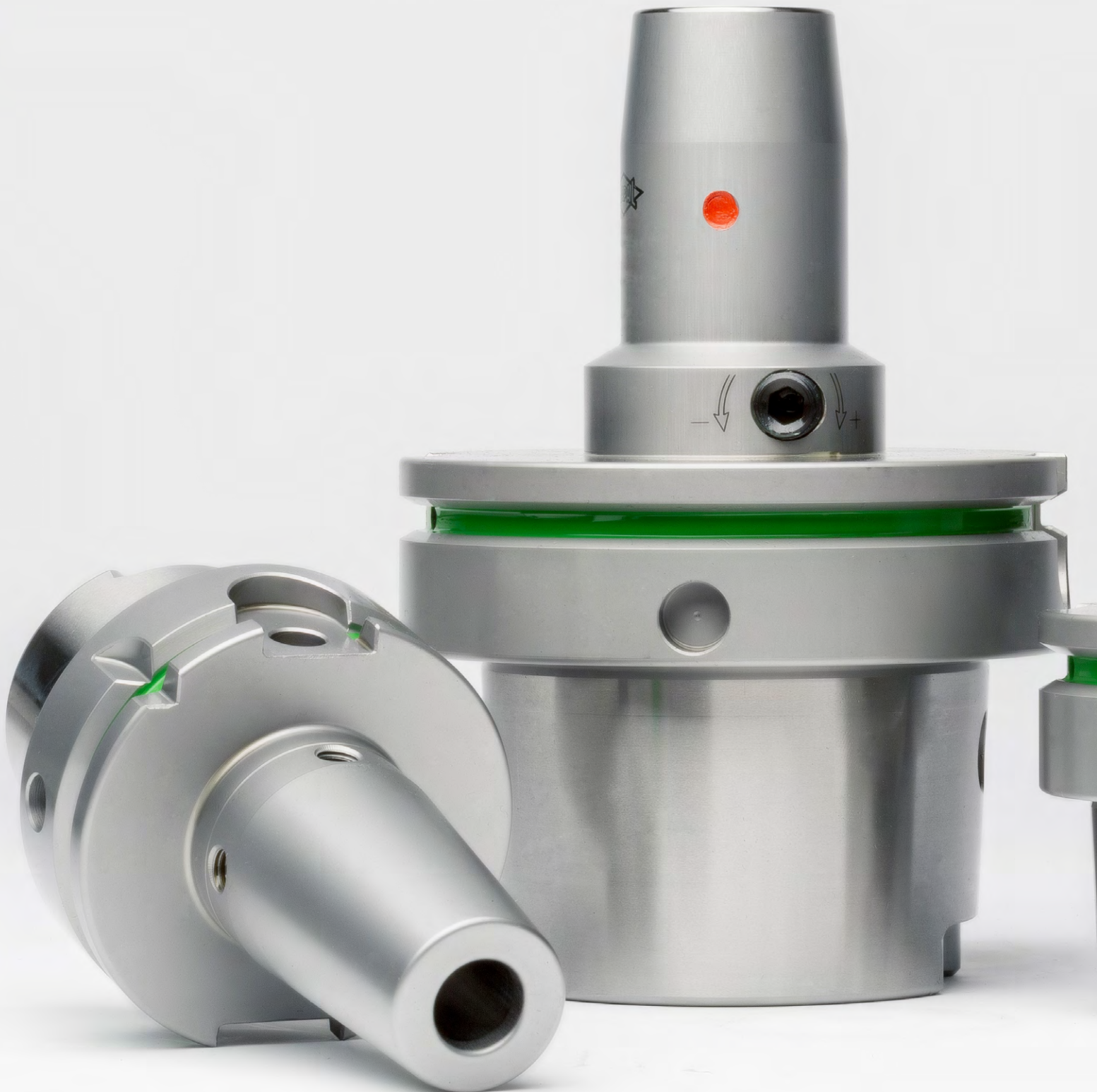



CHUCKS FOR MQL 1-CHANNEL SYSTEM



Automatic tool change



Hydraulic chucks HydroChuck with axial length adjustment _____ 10



Shrink chucks ThermoChuck _____ 13

Manual tool change



Hydraulic chucks HydroChuck with axial length adjustment _____ 16



Shrink chucks ThermoChuck _____ 19

1-channel system MQL hydraulic chucks HydroChuck

For automatic tool change, with axial tool length adjustment
Shank HSK-A in accordance with DIN 69893-1

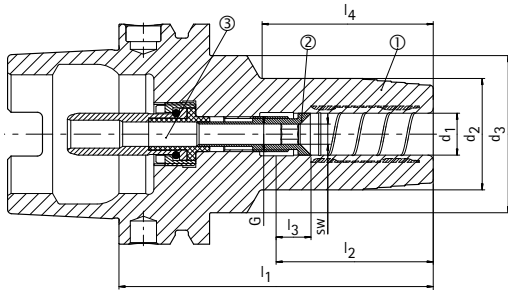

- ① Hydraulic chucks, HSK, MQL, body material | BDY
- ② Length adjustment screw, MQL | LS
- ③ Coolant supply unit, MQL, automatic | CU



Preferred series in stock

HSK-A	Dimensions							G	sw	Components			Specification	Order No.
	d ₁	d ₂	d ₃	l ₁	l ₂	l ₃	l ₄			BDY	LS	CU		
63	6	26	45	80	36	10	37	M10x1	4	30386549	30383941	10083281	MHC-HSK-A063-06-080-A-0-A-AAA	30386375
63	6	26	38	120	36	10	78	M5	2	30464609	30383945	10083281	MHC-HSK-A063-06-120-A-0-A-AAA	30470602
63	8	28	45	80	36	10	37,5	M10x1	4	30386550	10083384	10083281	MHC-HSK-A063-08-080-A-0-A-AAA	30386376
63	8	28	38	120	36	10	78,5	M7	3	30464610	10083394	10083281	MHC-HSK-A063-08-120-A-0-A-AAA	30470603
63	10	30	45	85	40	10	43,5	M10x1	4	30386551	10083385	10083281	MHC-HSK-A063-10-085-A-0-A-AAA	30386377
63	10	30	40	120	40	10	79	M8x1	4	30464611	10083401	10083281	MHC-HSK-A063-10-120-A-0-A-AAA	30470604
63	12	32	45	90	45	10	49	M10x1	5	30386552	10083386	10083281	MHC-HSK-A063-12-090-A-0-A-AAA	30386378
63	12	32	40	120	45	10	80,5	M10x1	5	30464612	10083409	10083281	MHC-HSK-A063-12-120-A-0-A-AAA	30470605
63	14	34	45	90	45	10	49,5	M10x1	5	30386553	10083387	10083281	MHC-HSK-A063-14-090-A-0-A-AAA	30386379
63	14	34	40	120	45	10	81	M10x1	5	30464613	10083410	10083281	MHC-HSK-A063-14-120-A-0-A-AAA	30470606
63	16	38	45	95	48	10	55,5	M12x1	5	30386554	10083388	10083281	MHC-HSK-A063-16-095-A-0-A-AAA	30386380
63	16	38	-	120	48	10	91,1	M12x1	5	30464614	10083411	10083281	MHC-HSK-A063-16-120-A-0-A-AAA	30470607
63	18	40	45	95	48	10	56	M12x1	5	30386555	10083389	10083281	MHC-HSK-A063-18-095-A-0-A-AAA	30386381
63	18	40	-	120	48	10	89,1	M12x1	5	30464615	10083412	10083281	MHC-HSK-A063-18-120-A-0-A-AAA	30470608
63	20	42	50	100	50	10	60,5	M16x1	5	30386556	10083390	10083281	MHC-HSK-A063-20-100-A-0-A-AAA	30386382
63	20	42	-	120	50	10	89,1	M16x1	5	30464616	10083413	10083281	MHC-HSK-A063-20-120-A-0-A-AAA	30470609
63	25	57	-	115	56	10	89	M16x1	5	30386557	10083391	10083281	MHC-HSK-A063-25-115-A-0-A-AAA	30386383
63	32	63	-	120	60	10	94	M16x1	5	30386558	10083392	10083281	MHC-HSK-A063-32-120-A-0-A-AAA	30386384
100	6	26	45	85	36	10	36,5	M10x1	4	30386569	30383941	10083283	MHC-HSK-A100-06-085-A-0-A-AAA	30386415
100	8	28	45	85	36	10	37	M10x1	4	30386570	10083384	10083283	MHC-HSK-A100-08-085-A-0-A-AAA	30386416
100	10	30	45	90	40	10	43	M10x1	4	30386571	10083385	10083283	MHC-HSK-A100-10-090-A-0-A-AAA	30386417
100	12	32	45	95	45	10	48,5	M10x1	5	30386572	10083386	10083283	MHC-HSK-A100-12-095-A-0-A-AAA	30386418
100	14	34	45	95	45	10	49	M10x1	5	30386573	10083387	10083283	MHC-HSK-A100-14-095-A-0-A-AAA	30386419
100	16	38	45	100	48	10	55	M12x1	5	30386574	10083388	10083283	MHC-HSK-A100-16-100-A-0-A-AAA	30386420
100	18	40	45	100	48	10	55,5	M12x1	5	30386575	10083389	10083283	MHC-HSK-A100-18-100-A-0-A-AAA	30386421
100	20	42	50	105	50	10	60	M16x1	5	30386576	10083390	10083283	MHC-HSK-A100-20-105-A-0-A-AAA	30386422
100	25	57	-	115	56	10	86	M16x1	5	30386577	10083391	10083283	MHC-HSK-A100-25-115-A-0-A-AAA	30386423
100	32	63	-	120	60	10	91	M16x1	5	30386578	10083392	10083283	MHC-HSK-A100-32-120-A-0-A-AAA	30386424

Dimensions in mm.

Use: For clamping tools with smooth cylindrical shanks according to DIN 1835 Form A, DIN 6535 Form HA as well as with recesses according to DIN 1835 Form B, E and DIN 6535 Form HB, HE directly and without reducing sleeve in the clamping diameter. The clamping diameter is designed for a shank tolerance h6.

Items included: Tool body, length adjustment screw and coolant unit as assembly. These components can also be ordered separately (see table).

Design: Longest tool lives and highest manufacturing quality on usage of smooth cylindrical shanks in accordance with DIN 1835 Form A and DIN 6535 Form HA. With a projection length of 2.5 x D (max. 50 mm) radial run-out accuracy 3 µm. On usage of cylindrical shanks with angled clamping surface (Form E and Form HE) the accuracy may be affected.

Different versions with chip available on request.
Balancing value: G 2.5 at 25,000 min⁻¹ as delivered.

1-channel system MQL hydraulic chucks HydroChuck

For automatic tool change, with axial tool length adjustment
Shank HSK-A in accordance with DIN 69893-1

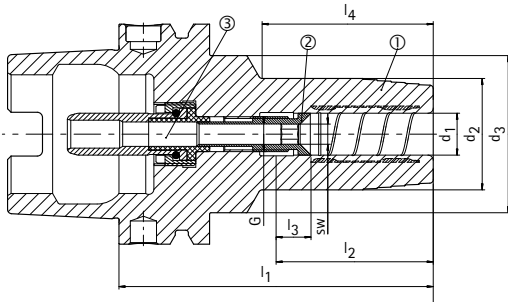

- ① Hydraulic chucks, HSK, MQL, body material | BDY
- ② Length adjustment screw, MQL | LS
- ③ Coolant supply unit, MQL, automatic | CU

Available on request

HSK-A	Dimensions							G	sw	Components			Specification	Order No.
	d ₁	d ₂	d ₃	l ₁	l ₂	l ₃	l ₄			BDY	LS	CU		
40	6	26	33,5	80	36	10	49	M7	3	30386529	10083370	10083279	MHC-HSK-A040-06-080-A-0-A-AAA	30386347
40	6	26	33,5	120	36	10	86	M5	2	30464569	30383945	10083279	MHC-HSK-A040-06-120-A-0-A-AAA	30470545
40	6	26	33,5	160	36	10	118	M5	2	30464575	30383945	10083279	MHC-HSK-A040-06-160-A-0-A-AAA	30470551
40	8	28	33,5	80	36	10	50,5	M7	3	30386530	10083371	10083279	MHC-HSK-A040-08-080-A-0-A-AAA	30386348
40	8	28	33,5	120	36	10	86,5	M7	3	30464570	10083394	10083279	MHC-HSK-A040-08-120-A-0-A-AAA	30470546
40	8	28	33,5	160	36	10	118	M7	3	30464576	10083394	10083279	MHC-HSK-A040-08-160-A-0-A-AAA	30470552
40	10	30	33,5	80	40	10	52	M8x1	3	30386531	10083372	10083279	MHC-HSK-A040-10-080-A-0-A-AAA	30386349
40	10	30	33,5	120	40	10	87	M8x1	3	30464571	10083395	10083279	MHC-HSK-A040-10-120-A-0-A-AAA	30470547
40	10	30	33,5	160	40	10	127	M8x1	3	30464577	10083395	10083279	MHC-HSK-A040-10-160-A-0-A-AAA	30470553
40	12	32	33,5	90	45	10	62	M10x1	3	30386532	10083373	10083279	MHC-HSK-A040-12-090-A-0-A-AAA	30386350
40	12	32	33,5	120	45	10	91,5	M10x1	3	30464572	10083396	10083279	MHC-HSK-A040-12-120-A-0-A-AAA	30470548
40	12	32	33,5	160	45	10	126	M10x1	3	30464578	10083396	10083279	MHC-HSK-A040-12-160-A-0-A-AAA	30470554
40	14	34	45	90	45	10	39,5	M10x1	3	30386533	10083374	10083279	MHC-HSK-A040-14-090-A-0-A-AAA	30386351
40	14	34	-	120	45	10	100	M10x1	3	30464573	10083397	10083279	MHC-HSK-A040-14-120-A-0-A-AAA	30470549
40	14	34	-	160	45	10	140	M10x1	3	30464579	10083397	10083279	MHC-HSK-A040-14-160-A-0-A-AAA	30470555
40	16	38	50	90	48	10	39	M12x1	3	30386534	10083375	10083279	MHC-HSK-A040-16-090-A-0-A-AAA	30386352
40	16	38	-	120	48	10	100	M12x1	3	30464574	10083398	10083279	MHC-HSK-A040-16-120-A-0-A-AAA	30470550
40	16	38	-	160	48	10	140	M12x1	3	30464580	10083398	10083279	MHC-HSK-A040-16-160-A-0-A-AAA	30470556
50	6	26	40	80	36	10	38,5	M8x1	4	30386541	10083376	10083280	MHC-HSK-A050-06-080-A-0-A-AAA	30386359
50	6	26	35	120	36	10	80	M5	2	30464593	30383945	10083280	MHC-HSK-A050-06-120-A-0-A-AAA	30470569
50	6	26	35	160	36	10	118	M5	2	30464601	30383945	10083280	MHC-HSK-A050-06-160-A-0-A-AAA	30470578
50	8	28	40	80	36	10	39	M8x1	4	30386542	10083377	10083280	MHC-HSK-A050-08-080-A-0-A-AAA	30386360
50	8	28	35	120	36	10	80	M7	3	30464594	10083394	10083280	MHC-HSK-A050-08-120-A-0-A-AAA	30470570
50	8	28	35	160	36	10	118	M7	3	30464602	10083394	10083280	MHC-HSK-A050-08-160-A-0-A-AAA	30470579
50	10	30	40	85	40	10	44,5	M8x1	4	30386543	10083378	10083280	MHC-HSK-A050-10-085-A-0-A-AAA	30386361
50	10	30	38	120	40	10	80	M8x1	4	30464595	10083401	10083280	MHC-HSK-A050-10-120-A-0-A-AAA	30470571
50	10	30	38	160	40	10	120	M8x1	4	30464603	10083401	10083280	MHC-HSK-A050-10-160-A-0-A-AAA	30470580
50	12	32	40	90	45	10	53	M10x1	4	30386544	10083379	10083280	MHC-HSK-A050-12-090-A-0-A-AAA	30386362
50	12	32	38	120	45	10	81	M10x1	4	30464596	10083402	10083280	MHC-HSK-A050-12-120-A-0-A-AAA	30470572
50	12	32	38	160	45	10	121	M10x1	4	30464604	10083402	10083280	MHC-HSK-A050-12-160-A-0-A-AAA	30470581
50	14	34	40	90	45	10	54,5	M10x1	4	30386545	10083380	10083280	MHC-HSK-A050-14-090-A-0-A-AAA	30386363
50	14	34	38	120	45	10	81,5	M10x1	4	30464597	10083403	10083280	MHC-HSK-A050-14-120-A-0-A-AAA	30470574
50	14	34	38	160	45	10	121,5	M10x1	4	30464605	10083403	10083280	MHC-HSK-A050-14-160-A-0-A-AAA	30470582
50	16	38	41,5	95	48	10	61	M12x1	4	30386546	10083381	10083280	MHC-HSK-A050-16-095-A-0-A-AAA	30386364
50	16	38	-	120	48	10	94	M12x1	4	30464598	10083404	10083280	MHC-HSK-A050-16-120-A-0-A-AAA	30470575
50	16	38	-	160	48	10	134	M12x1	4	30464606	10083404	10083280	MHC-HSK-A050-16-160-A-0-A-AAA	30470583
50	18	40	41,5	95	48	10	62,5	M12x1	4	30386547	10083382	10083280	MHC-HSK-A050-18-095-A-0-A-AAA	30386365
50	18	40	-	120	48	10	94	M12x1	4	30464599	10083405	10083280	MHC-HSK-A050-18-120-A-0-A-AAA	30470576
50	18	40	-	160	48	10	134	M12x1	4	30464607	10083405	10083280	MHC-HSK-A050-18-160-A-0-A-AAA	30470584
50	20	42	55	100	50	10	42	M16x1	4	30386548	10083383	10083280	MHC-HSK-A050-20-100-A-0-A-AAA	30386366
50	20	42	-	120	50	10	94	M16x1	4	30464600	10083406	10083280	MHC-HSK-A050-20-120-A-0-A-AAA	30470577
50	20	42	-	160	50	10	134	M16x1	4	30464608	10083406	10083280	MHC-HSK-A050-20-160-A-0-A-AAA	30470585

1-channel system MQL hydraulic chucks HydroChuck | Available on request

HSK-A	Dimensions							G	sw	Components			Specification	Order No.
	d ₁	d ₂	d ₃	l ₁	l ₂	l ₃	l ₄			BDY	LS	CU		
63	6	26	38	160	36	10	118	M5	2	30464617	30383945	10083281	MHC-HSK-A063-06-160-A-0-A-AAA	30470610
63	6	30	38	200	36	10	155	M5	2	30464627	30383945	10083281	MHC-HSK-A063-06-200-A-0-A-AAA	30470620
63	8	28	38	160	36	10	118	M7	3	30464618	10083394	10083281	MHC-HSK-A063-08-160-A-0-A-AAA	30470611
63	8	32	38	200	36	10	156	M7	3	30464628	10083394	10083281	MHC-HSK-A063-08-200-A-0-A-AAA	30470621
63	10	30	40	160	40	10	115	M8x1	4	30464619	10083401	10083281	MHC-HSK-A063-10-160-A-0-A-AAA	30470612
63	10	31	40	200	40	10	155	M8x1	4	30464629	10083401	10083281	MHC-HSK-A063-10-200-A-0-A-AAA	30470622
63	12	32	40	160	45	10	121	M10x1	5	30464620	10083409	10083281	MHC-HSK-A063-12-160-A-0-A-AAA	30470613
63	12	32	40	200	45	10	161	M10x1	5	30464630	10083409	10083281	MHC-HSK-A063-12-200-A-0-A-AAA	30470623
63	14	34	40	160	45	10	121	M10x1	5	30464621	10083410	10083281	MHC-HSK-A063-14-160-A-0-A-AAA	30470614
63	14	34	40	200	45	10	161	M10x1	5	30464631	10083410	10083281	MHC-HSK-A063-14-200-A-0-A-AAA	30470624
63	16	38	-	160	48	10	131	M12x1	5	30464622	10083411	10083281	MHC-HSK-A063-16-160-A-0-A-AAA	30470615
63	16	38	-	200	48	10	171	M12x1	5	30464632	10083411	10083281	MHC-HSK-A063-16-200-A-0-A-AAA	30470625
63	18	40	-	160	48	10	129	M12x1	5	30464623	10083412	10083281	MHC-HSK-A063-18-160-A-0-A-AAA	30470616
63	18	40	-	200	48	10	169	M12x1	5	30464633	10083412	10083281	MHC-HSK-A063-18-200-A-0-A-AAA	30470626
63	20	42	-	160	50	10	129	M16x1	5	30464624	10083413	10083281	MHC-HSK-A063-20-160-A-0-A-AAA	30470617
63	20	42	-	200	50	10	169	M16x1	5	30464634	10083413	10083281	MHC-HSK-A063-20-200-A-0-A-AAA	30470627
63	25	57	-	160	56	10	134	M16x1	5	30464625	10083414	10083281	MHC-HSK-A063-25-160-A-0-A-AAA	30470618
63	25	57	-	200	56	10	174	M16x1	5	30464635	10083414	10083281	MHC-HSK-A063-25-200-A-0-A-AAA	30470628
63	32	63	-	160	60	10	134	M16x1	5	30464626	10083415	10083281	MHC-HSK-A063-32-160-A-0-A-AAA	30470619
63	32	63	-	200	60	10	174	M16x1	5	30464636	10083415	10083281	MHC-HSK-A063-32-200-A-0-A-AAA	30470629
100	6	26	38	120	36	10	73,5	M5	2	30464665	30383945	10083283	MHC-HSK-A100-06-120-A-0-A-AAA	30470714
100	6	26	38	160	36	10	113,5	M5	2	30464673	30383945	10083283	MHC-HSK-A100-06-160-A-0-A-AAA	30470722
100	6	30	38	200	36	10	155	M5	2	30464683	30383945	10083283	MHC-HSK-A100-06-200-A-0-A-AAA	30470732
100	8	28	38	120	36	10	74	M7	3	30464666	10083394	10083283	MHC-HSK-A100-08-120-A-0-A-AAA	30470715
100	8	28	38	160	36	10	114	M7	3	30464674	10083394	10083283	MHC-HSK-A100-08-160-A-0-A-AAA	30470723
100	8	32	38	200	36	10	155,5	M7	3	30464684	10083394	10083283	MHC-HSK-A100-08-200-A-0-A-AAA	30470733
100	10	30	40	120	40	10	74,5	M8x1	4	30464667	10083401	10083283	MHC-HSK-A100-10-120-A-0-A-AAA	30470716
100	10	30	40	160	40	10	114,5	M8x1	4	30464675	10083401	10083283	MHC-HSK-A100-10-160-A-0-A-AAA	30470724
100	10	31	40	200	40	10	155	M8x1	4	30464685	10083401	10083283	MHC-HSK-A100-10-200-A-0-A-AAA	30470734
100	12	32	40	120	45	10	75	M10x1	5	30464668	10083409	10083283	MHC-HSK-A100-12-120-A-0-A-AAA	30470717
100	12	32	40	160	45	10	115	M10x1	5	30464676	10083409	10083283	MHC-HSK-A100-12-160-A-0-A-AAA	30470725
100	12	32	40	200	45	10	155	M10x1	5	30464686	10083409	10083283	MHC-HSK-A100-12-200-A-0-A-AAA	30470735
100	14	34	40	120	45	10	75,5	M10x1	5	30464669	10083410	10083283	MHC-HSK-A100-14-120-A-0-A-AAA	30470718
100	14	34	40	160	45	10	115,5	M10x1	5	30464677	10083410	10083283	MHC-HSK-A100-14-160-A-0-A-AAA	30470726
100	14	34	40	200	45	10	155,5	M10x1	5	30464687	10083410	10083283	MHC-HSK-A100-14-200-A-0-A-AAA	30470736
100	16	38	-	120	48	10	81,1	M12x1	5	30464670	10083411	10083283	MHC-HSK-A100-16-120-A-0-A-AAA	30470719
100	16	38	-	160	48	10	121,1	M12x1	5	30464678	10083411	10083283	MHC-HSK-A100-16-160-A-0-A-AAA	30470727
100	16	38	-	200	48	10	161,1	M12x1	5	30464688	10083411	10083283	MHC-HSK-A100-16-200-A-0-A-AAA	30470737
100	18	40	-	120	48	10	81,1	M12x1	5	30464671	10083412	10083283	MHC-HSK-A100-18-120-A-0-A-AAA	30470720
100	18	40	-	160	48	10	121,1	M12x1	5	30464679	10083412	10083283	MHC-HSK-A100-18-160-A-0-A-AAA	30470728
100	18	40	-	200	48	10	161,1	M12x1	5	30464689	10083412	10083283	MHC-HSK-A100-18-200-A-0-A-AAA	30470738
100	20	42	-	120	50	10	81,1	M16x1	5	30464672	10083413	10083283	MHC-HSK-A100-20-120-A-0-A-AAA	30470721
100	20	42	-	160	50	10	121,1	M16x1	5	30464680	10083413	10083283	MHC-HSK-A100-20-160-A-0-A-AAA	30470729
100	20	42	-	200	50	10	161,1	M16x1	5	30464690	10083413	10083283	MHC-HSK-A100-20-200-A-0-A-AAA	30470739
100	25	57	-	160	56	10	131	M16x1	5	30464681	10083414	10083283	MHC-HSK-A100-25-160-A-0-A-AAA	30470730
100	25	57	-	200	56	10	171	M16x1	5	30464691	10083414	10083283	MHC-HSK-A100-25-200-A-0-A-AAA	30470740
100	32	63	-	160	60	10	131	M16x1	5	30464682	10083415	10083283	MHC-HSK-A100-32-160-A-0-A-AAA	30470731
100	32	63	-	200	60	10	171	M16x1	5	30464692	10083415	10083283	MHC-HSK-A100-32-200-A-0-A-AAA	30470741

Dimensions in mm.

Use: For clamping tools with smooth cylindrical shanks according to DIN 1835 Form A, DIN 6535 Form HA as well as with recesses according to DIN 1835 Form B, E and DIN 6535 Form HB, HE directly and without reducing sleeve in the clamping diameter. The clamping diameter is designed for a shank tolerance h6.

Items included: Tool body, length adjustment screw and coolant unit as assembly.

These components can also be ordered separately. (see table)

Design: Longest tool lives and highest manufacturing quality on usage of smooth cylindrical shanks in accordance with DIN 1835 Form A and DIN 6535 Form HA.

With a projection length of 2.5 x D (max. 50 mm) radial run-out accuracy 3 µm. On usage of cylindrical shanks with angled clamping surface (Form E and Form HE) the accuracy may be affected.

Different versions with chip available on request.

Balancing value: G 2.5 at 25,000 min⁻¹ as delivered.

1-channel system MQL shrink chucks ThermoChuck

For automatic tool change, with axial tool length adjustment
Shank HSK-A in accordance with DIN 69893-1

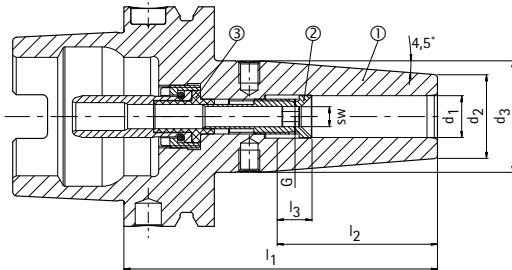

- ① Shrink chuck, HSK, MQL, tool body | BDY
- ② Length adjustment screw, MQL | LS
- ③ Coolant supply unit, MQL, automatic | CU



Preferred series in stock

HSK-A	Dimensions						G	sw	Components			Specification	Order No.
	d ₁	d ₂	d ₃	l ₁	l ₂	l ₃			BDY	LS	CU		
63	6	21	27	80	36	10	M10x1	4	10083235	30383941	10083281	MTC-HSK-A063-06-080-A-0-A-AAA	30380921
63	6	21	27	120	36	10	M5	2	30386128	30383945	10083281	MTC-HSK-A063-06-120-A-0-A-AAA	30385484
63	8	21	27	80	36	10	M10x1	4	10083236	10083384	10083281	MTC-HSK-A063-08-080-A-0-A-AAA	30380922
63	8	21	27	120	36	10	M7	3	30386129	10083394	10083281	MTC-HSK-A063-08-120-A-0-A-AAA	30385485
63	10	24	32	85	40	10	M10x1	4	10083237	10083385	10083281	MTC-HSK-A063-10-085-A-0-A-AAA	30380923
63	10	24	32	120	40	10	M8x1	4	30386800	10083401	10083281	MTC-HSK-A063-10-120-A-0-A-AAA	30385486
63	12	24	32	90	45	10	M10x1	5	10083238	10083386	10083281	MTC-HSK-A063-12-090-A-0-A-AAA	30380924
63	12	24	32	120	45	10	M10x1	5	10096023	10083409	10083281	MTC-HSK-A063-12-120-A-0-A-AAA	30340561
63	14	27	34	90	45	10	M10x1	5	10083239	10083387	10083281	MTC-HSK-A063-14-090-A-0-A-AAA	30380925
63	14	27	34	120	45	10	M10x1	5	30192712	10083410	10083281	MTC-HSK-A063-14-120-A-0-A-AAA	30340562
63	16	27	34	95	48	10	M12x1	5	10083240	10083388	10083281	MTC-HSK-A063-16-095-A-0-A-AAA	30380926
63	16	27	34	120	48	10	M12x1	5	10107287	10083411	10083281	MTC-HSK-A063-16-120-A-0-A-AAA	30340563
63	18	33	42	95	48	10	M12x1	5	10083241	10083389	10083281	MTC-HSK-A063-18-095-A-0-A-AAA	30380927
63	18	33	42	120	48	10	M12x1	5	10107292	10083412	10083281	MTC-HSK-A063-18-120-A-0-A-AAA	30263986
63	20	33	42	100	50	10	M16x1	5	10083242	10083390	10083281	MTC-HSK-A063-20-100-A-0-A-AAA	30380928
63	20	33	42	120	50	10	M16x1	5	30192716	10083413	10083281	MTC-HSK-A063-20-120-A-0-A-AAA	30340564
63	25	44	53	115	56	10	M16x1	5	10083243	10083391	10083281	MTC-HSK-A063-25-115-A-0-A-AAA	30380929
63	32	44	53	120	60	10	M16x1	5	10083244	10083392	10083281	MTC-HSK-A063-32-120-A-0-A-AAA	30380930
100	6	21	27	85	36	10	M10x1	4	10083255	30383941	10083283	MTC-HSK-A100-06-085-A-0-A-AAA	30381074
100	8	21	27	85	36	10	M10x1	4	10083256	10083384	10083283	MTC-HSK-A100-08-085-A-0-A-AAA	30381075
100	10	24	32	90	40	10	M10x1	4	10083257	10083385	10083283	MTC-HSK-A100-10-090-A-0-A-AAA	30381076
100	12	24	32	95	45	10	M10x1	5	10083258	10083386	10083283	MTC-HSK-A100-12-095-A-0-A-AAA	30381077
100	14	27	34	95	45	10	M10x1	5	10083259	10083387	10083283	MTC-HSK-A100-14-095-A-0-A-AAA	30381078
100	16	27	34	100	48	10	M12x1	5	10083260	10083388	10083283	MTC-HSK-A100-16-100-A-0-A-AAA	30381079
100	18	33	42	100	48	10	M12x1	5	10083261	10083389	10083283	MTC-HSK-A100-18-100-A-0-A-AAA	30381080
100	20	33	42	105	50	10	M16x1	5	10083262	10083390	10083283	MTC-HSK-A100-20-105-A-0-A-AAA	30381081
100	25	44	53	115	56	10	M16x1	5	10083263	10083391	10083283	MTC-HSK-A100-25-115-A-0-A-AAA	30381082
100	32	44	53	120	60	10	M16x1	5	10083264	10083392	10083283	MTC-HSK-A100-32-120-A-0-A-AAA	30381083

Dimensions in mm.

Items included: Tool body, length adjustment screw and coolant unit as assembly.
These components can also be ordered separately (see table).

Design: Permissible run-out deviation on the hollow taper shank in relation to the clamping diameter $d_1 = 3 \mu\text{m}$. The clamping diameter is designed for a shank tolerance of h6.

Different versions with chip available on request.
Balancing value: G 2.5 at 25,000 min^{-1} as delivered.

1-channel system MQL shrink chucks ThermoChuck

For automatic tool change, with axial tool length adjustment
Shank HSK-A in accordance with DIN 69893-1

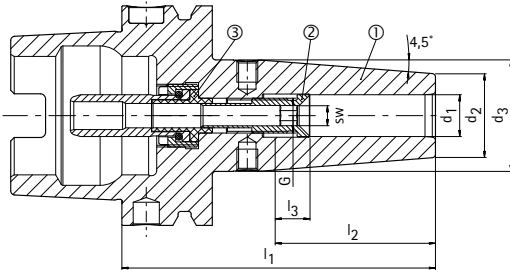

- ① Shrink chuck, HSK, MQL, tool body | BDY
- ② Length adjustment screw, MQL | LS
- ③ Coolant supply unit, MQL, automatic | CU



Available on request

HSK-A	Dimensions						G	sw	Components			Specification	Order No.
	d ₁	d ₂	d ₃	l ₁	l ₂	l ₃			BDY	LS	CU		
40	6	21	27	80	36	10	M7	3	10083221	10083370	10083279	MTC-HSK-A040-06-080-A-0-A-AAA	30335292
40	8	21	27	80	36	10	M7	3	10083222	10083371	10083279	MTC-HSK-A040-08-080-A-0-A-AAA	30335293
40	10	24	32	80	40	10	M8x1	3	10083223	10083372	10083279	MTC-HSK-A040-10-080-A-0-A-AAA	30335294
40	12	24	32	90	45	10	M10x1	3	10083224	10083373	10083279	MTC-HSK-A040-12-090-A-0-A-AAA	30335295
40	14	27	34	90	45	10	M10x1	3	10083225	10083374	10083279	MTC-HSK-A040-14-090-A-0-A-AAA	30335296
40	16	27	34	90	48	10	M12x1	3	10083226	10083375	10083279	MTC-HSK-A040-16-090-A-0-A-AAA	30335297
50	6	21	27	80	36	10	M8x1	4	10083227	10083376	10083280	MTC-HSK-A050-06-080-A-0-A-AAA	30335328
50	8	21	27	80	36	10	M8x1	4	10083228	10083377	10083280	MTC-HSK-A050-08-080-A-0-A-AAA	30335329
50	10	24	32	85	40	10	M8x1	4	10083229	10083378	10083280	MTC-HSK-A050-10-085-A-0-A-AAA	30335330
50	12	24	32	90	45	10	M10x1	4	10083230	10083379	10083280	MTC-HSK-A050-12-090-A-0-A-AAA	30335331
50	14	27	34	90	45	10	M10x1	4	10083231	10083380	10083280	MTC-HSK-A050-14-090-A-0-A-AAA	30335332
50	16	27	34	95	48	10	M12x1	4	10083232	10083381	10083280	MTC-HSK-A050-16-095-A-0-A-AAA	30335333
50	18	33	42	95	48	10	M12x1	4	10083233	10083382	10083280	MTC-HSK-A050-18-095-A-0-A-AAA	30335334
50	20	33	42	100	50	10	M16x1	4	10083234	10083383	10083280	MTC-HSK-A050-20-100-A-0-A-AAA	30335335
63	6	21	27	160	36	10	M5	2	30386130	30383945	10083281	MTC-HSK-A063-06-160-A-0-A-AAA	30385490
63	6	21	27	200	36	10	M5	2	30386132	30383945	10083281	MTC-HSK-A063-06-200-A-0-A-AAA	30385496
63	8	21	27	160	36	10	M7	3	30386131	10083394	10083281	MTC-HSK-A063-08-160-A-0-A-AAA	30385491
63	8	21	27	200	36	10	M7	3	30386133	10083394	10083281	MTC-HSK-A063-08-200-A-0-A-AAA	30385497
63	10	24	32	160	40	10	M8x1	4	30386802	10083401	10083281	MTC-HSK-A063-10-160-A-0-A-AAA	30385492
63	10	24	32	200	40	10	M8x1	4	30386134	10083401	10083281	MTC-HSK-A063-10-200-A-0-A-AAA	30385498
63	12	24	32	160	45	10	M10x1	5	30197953	10083409	10083281	MTC-HSK-A063-12-160-A-0-A-AAA	30340566
63	12	24	32	200	45	10	M10x1	5	10107285	10083409	10083281	MTC-HSK-A063-12-200-A-0-A-AAA	30340573
63	14	27	34	160	45	10	M10x1	5	10096025	10083410	10083281	MTC-HSK-A063-14-160-A-0-A-AAA	30340567
63	14	27	34	200	45	10	M10x1	5	10096026	10083410	10083281	MTC-HSK-A063-14-200-A-0-A-AAA	30340574
63	16	27	34	160	48	10	M12x1	5	10107288	10083411	10083281	MTC-HSK-A063-16-160-A-0-A-AAA	30340568
63	16	27	34	200	48	10	M12x1	5	10107289	10083411	10083281	MTC-HSK-A063-16-200-A-0-A-AAA	30340575
63	18	33	42	160	48	10	M12x1	5	10096027	10083412	10083281	MTC-HSK-A063-18-160-A-0-A-AAA	30340570
63	18	33	42	200	48	10	M12x1	5	10107293	10083412	10083281	MTC-HSK-A063-18-200-A-0-A-AAA	30340576
63	20	33	42	160	50	10	M16x1	5	10107294	10083413	10083281	MTC-HSK-A063-20-160-A-0-A-AAA	30263987
63	20	33	42	200	50	10	M16x1	5	10107295	10083413	10083281	MTC-HSK-A063-20-200-A-0-A-AAA	30340577
63	25	44	53	160	56	10	M16x1	5	10107296	10083414	10083281	MTC-HSK-A063-25-160-A-0-A-AAA	30296689
63	25	44	53	200	56	10	M16x1	5	10107297	10083414	10083281	MTC-HSK-A063-25-200-A-0-A-AAA	30340578
63	32	44	53	160	60	10	M16x1	5	10107298	10083415	10083281	MTC-HSK-A063-32-160-A-0-A-AAA	30340571
63	32	44	53	200	60	10	M16x1	5	10107299	10083415	10083281	MTC-HSK-A063-32-200-A-0-A-AAA	30340579
80	6	21	27	85	36	10	M10x1	4	10083245	30383941	10083282	MTC-HSK-A080-06-085-A-0-A-AAA	30380997
80	8	21	27	85	36	10	M10x1	4	10083246	10083384	10083282	MTC-HSK-A080-08-085-A-0-A-AAA	30380998
80	10	24	32	90	40	10	M10x1	4	10083247	10083385	10083282	MTC-HSK-A080-10-090-A-0-A-AAA	30380999
80	12	24	32	95	45	10	M10x1	5	10083248	10083386	10083282	MTC-HSK-A080-12-095-A-0-A-AAA	30381000
80	14	27	34	95	45	10	M10x1	5	10083249	10083387	10083282	MTC-HSK-A080-14-095-A-0-A-AAA	30381001

1-channel system MQL shrink chucks ThermoChuck | Available on request

HSK-A	Dimensions						G	sw	Components			Specification	Order No.
	d ₁	d ₂	d ₃	l ₁	l ₂	l ₃			BDY	LS	CU		
80	16	27	34	100	48	10	M12x1	5	10083250	10083388	10083282	MTC-HSK-A080-16-100-A-0-A-AAA	30381002
80	18	33	42	100	48	10	M12x1	5	10083251	10083389	10083282	MTC-HSK-A080-18-100-A-0-A-AAA	30381003
80	20	33	42	105	50	10	M16x1	5	10083252	10083390	10083282	MTC-HSK-A080-20-105-A-0-A-AAA	30381004
80	25	44	53	115	56	10	M16x1	5	10083253	10083391	10083282	MTC-HSK-A080-25-115-A-0-A-AAA	30381005
80	32	44	53	120	60	10	M16x1	5	10083254	10083392	10083282	MTC-HSK-A080-32-120-A-0-A-AAA	30381006
100	6	21	27	120	36	10	M5	2	30386144	30383945	10083283	MTC-HSK-A100-06-120-A-0-A-AAA	30385520
100	6	21	27	160	36	10	M5	2	30386147	30383945	10083283	MTC-HSK-A100-06-160-A-0-A-AAA	30385526
100	6	21	27	200	36	10	M5	2	30386150	30383945	10083283	MTC-HSK-A100-06-200-A-0-A-AAA	30385532
100	8	21	27	120	36	10	M7	3	30386145	10083394	10083283	MTC-HSK-A100-08-120-A-0-A-AAA	30385521
100	8	21	27	160	36	10	M7	3	30386148	10083394	10083283	MTC-HSK-A100-08-160-A-0-A-AAA	30385527
100	8	21	27	200	36	10	M7	3	30386151	10083394	10083283	MTC-HSK-A100-08-200-A-0-A-AAA	30385533
100	10	24	32	120	40	10	M8x1	4	30386146	10083401	10083283	MTC-HSK-A100-10-120-A-0-A-AAA	30385522
100	10	24	32	160	40	10	M8x1	4	30386149	10083401	10083283	MTC-HSK-A100-10-160-A-0-A-AAA	30385528
100	10	24	32	200	40	10	M8x1	4	30386152	10083401	10083283	MTC-HSK-A100-10-200-A-0-A-AAA	30385534
100	12	24	32	120	45	10	M10x1	5	30253151	10083409	10083283	MTC-HSK-A100-12-120-A-0-A-AAA	30480187
100	12	24	32	160	45	10	M10x1	5	30302825	10083409	10083283	MTC-HSK-A100-12-160-A-0-A-AAA	30480198
100	12	24	32	200	45	10	M10x1	5	30253152	10083409	10083283	MTC-HSK-A100-12-200-A-0-A-AAA	30480212
100	14	27	34	120	45	10	M10x1	5	30254306	10083410	10083283	MTC-HSK-A100-14-120-A-0-A-AAA	30480188
100	14	27	34	160	45	10	M10x1	5	30302826	10083410	10083283	MTC-HSK-A100-14-160-A-0-A-AAA	30480199
100	14	27	34	200	45	10	M10x1	5	30303050	10083410	10083283	MTC-HSK-A100-14-200-A-0-A-AAA	30480213
100	16	27	34	120	48	10	M12x1	5	30302821	10083411	10083283	MTC-HSK-A100-16-120-A-0-A-AAA	30480189
100	16	27	34	160	48	10	M12x1	5	30302827	10083411	10083283	MTC-HSK-A100-16-160-A-0-A-AAA	30480200
100	16	27	34	200	48	10	M12x1	5	30302831	10083411	10083283	MTC-HSK-A100-16-200-A-0-A-AAA	30480214
100	18	33	42	120	48	10	M12x1	5	30253155	10083412	10083283	MTC-HSK-A100-18-120-A-0-A-AAA	30480190
100	18	33	42	160	48	10	M12x1	5	10096879	10083412	10083283	MTC-HSK-A100-18-160-A-0-A-AAA	30480201
100	18	33	42	200	48	10	M12x1	5	10107134	10083412	10083283	MTC-HSK-A100-18-200-A-0-A-AAA	30480215
100	20	33	42	120	50	10	M16x1	5	30302822	10083413	10083283	MTC-HSK-A100-20-120-A-0-A-AAA	30480192
100	20	33	42	160	50	10	M16x1	5	10096880	10083413	10083283	MTC-HSK-A100-20-160-A-0-A-AAA	30480202
100	20	33	42	200	50	10	M16x1	5	30302832	10083413	10083283	MTC-HSK-A100-20-200-A-0-A-AAA	30480216
100	25	44	53	160	56	10	M16x1	5	30258455	10083414	10083283	MTC-HSK-A100-25-160-A-0-A-AAA	30480203
100	25	44	53	200	56	10	M16x1	5	30302833	10083414	10083283	MTC-HSK-A100-25-200-A-0-A-AAA	30480217
100	32	44	53	160	60	10	M16x1	5	30303048	10083415	10083283	MTC-HSK-A100-32-160-A-0-A-AAA	30480204
100	32	44	53	200	60	10	M16x1	5	30302834	10083415	10083283	MTC-HSK-A100-32-200-A-0-A-AAA	30480218

Dimensions in mm.

Items included: Tool body, length adjustment screw and coolant unit as assembly.

These components can also be ordered separately. (see table)

Design: Permissible run-out deviation on the hollow taper shank in relation to the clamping diameter $d_1 = 3 \mu\text{m}$. The clamping diameter is designed for a shank tolerance of h6.

Different versions with chip available on request.

Balancing value: G 2.5 at 25,000 min^{-1} as delivered.

1-channel system MQL hydraulic chucks HydroChuck

For manual tool change, with axial tool length adjustment
Shank HSK-A in accordance with DIN 69893-1

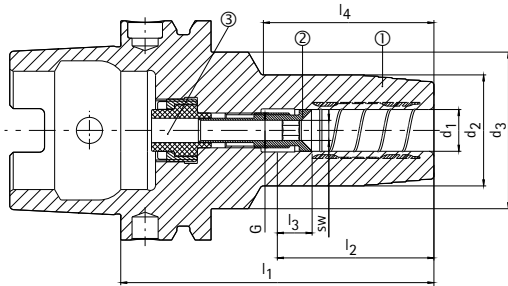

- ① Hydraulic chucks, HSK, MQL, body material | BDY
- ② Length adjustment screw, MQL | LS
- ③ Coolant supply unit, MQL, manual | CU



Available on request

HSK-A	Dimensions							G	sw	Components			Specification	Order No.
	d ₁	d ₂	d ₃	l ₁	l ₂	l ₃	l ₄			BDY	LS	CU		
40	6	26	33,5	80	36	10	49	M7	3	30386529	10083370	10083268	MHC-HSK-A040-06-080-B-0-A-AAA	30386439
40	6	26	33,5	120	36	10	86	M5	2	30464569	30383945	10083268	MHC-HSK-A040-06-120-B-0-A-AAA	30470779
40	6	26	33,5	160	36	10	118	M5	2	30464575	30383945	10083268	MHC-HSK-A040-06-160-B-0-A-AAA	30470785
40	8	28	33,5	80	36	10	50,5	M7	3	30386530	10083371	10083268	MHC-HSK-A040-08-080-B-0-A-AAA	30386440
40	8	28	33,5	120	36	10	86,5	M7	3	30464570	10083394	10083268	MHC-HSK-A040-08-120-B-0-A-AAA	30470780
40	8	28	33,5	160	36	10	118	M7	3	30464576	10083394	10083268	MHC-HSK-A040-08-160-B-0-A-AAA	30470786
40	10	30	33,5	80	40	10	52	M8x1	3	30386531	10083372	10083268	MHC-HSK-A040-10-080-B-0-A-AAA	30386441
40	10	30	33,5	120	40	10	87	M8x1	3	30464571	10083395	10083268	MHC-HSK-A040-10-120-B-0-A-AAA	30470781
40	10	30	33,5	160	40	10	127	M8x1	3	30464577	10083395	10083268	MHC-HSK-A040-10-160-B-0-A-AAA	30470787
40	12	32	33,5	90	45	10	62	M10x1	3	30386532	10083373	10083268	MHC-HSK-A040-12-090-B-0-A-AAA	30386442
40	12	32	33,5	120	45	10	91,5	M10x1	3	30464572	10083396	10083268	MHC-HSK-A040-12-120-B-0-A-AAA	30470782
40	12	32	33,5	160	45	10	126	M10x1	3	30464578	10083396	10083268	MHC-HSK-A040-12-160-B-0-A-AAA	30470788
40	14	34	45	90	45	10	39,5	M10x1	3	30386533	10083374	10083268	MHC-HSK-A040-14-090-B-0-A-AAA	30386443
40	14	34	-	120	45	10	100	M10x1	3	30464573	10083397	10083268	MHC-HSK-A040-14-120-B-0-A-AAA	30470783
40	14	34	-	160	45	10	140	M10x1	3	30464579	10083397	10083268	MHC-HSK-A040-14-160-B-0-A-AAA	30470789
40	16	38	50	90	48	10	39	M12x1	3	30386534	10083375	10083268	MHC-HSK-A040-16-090-B-0-A-AAA	30386444
40	16	38	-	120	48	10	100	M12x1	3	30464574	10083398	10083268	MHC-HSK-A040-16-120-B-0-A-AAA	30470784
40	16	38	-	160	48	10	140	M12x1	3	30464580	10083398	10083268	MHC-HSK-A040-16-160-B-0-A-AAA	30470790
50	6	26	40	80	36	10	38,5	M8x1	4	30386541	10083376	10083269	MHC-HSK-A050-06-080-B-0-A-AAA	30386445
50	6	26	35	120	36	10	80	M5	2	30464593	30383945	10083269	MHC-HSK-A050-06-120-B-0-A-AAA	30470791
50	6	26	35	160	36	10	118	M5	2	30464601	30383945	10083269	MHC-HSK-A050-06-160-B-0-A-AAA	30470799
50	8	28	40	80	36	10	39	M8x1	4	30386542	10083377	10083269	MHC-HSK-A050-08-080-B-0-A-AAA	30386446
50	8	28	35	120	36	10	80	M7	3	30464594	10083394	10083269	MHC-HSK-A050-08-120-B-0-A-AAA	30470792
50	8	28	35	160	36	10	118	M7	3	30464602	10083394	10083269	MHC-HSK-A050-08-160-B-0-A-AAA	30470800
50	10	30	40	85	40	10	44,5	M8x1	4	30386543	10083378	10083269	MHC-HSK-A050-10-085-B-0-A-AAA	30386447
50	10	30	38	120	40	10	80	M8x1	4	30464595	10083401	10083269	MHC-HSK-A050-10-120-B-0-A-AAA	30470793
50	10	30	38	160	40	10	120	M8x1	4	30464603	10083401	10083269	MHC-HSK-A050-10-160-B-0-A-AAA	30470801
50	12	32	40	90	45	10	53	M10x1	4	30386544	10083379	10083269	MHC-HSK-A050-12-090-B-0-A-AAA	30386448
50	12	32	38	120	45	10	81	M10x1	4	30464596	10083402	10083269	MHC-HSK-A050-12-120-B-0-A-AAA	30470794
50	12	32	38	160	45	10	121	M10x1	4	30464604	10083402	10083269	MHC-HSK-A050-12-160-B-0-A-AAA	30470802
50	14	34	40	90	45	10	54,5	M10x1	4	30386545	10083380	10083269	MHC-HSK-A050-14-090-B-0-A-AAA	30386449
50	14	34	38	120	45	10	81,5	M10x1	4	30464597	10083403	10083269	MHC-HSK-A050-14-120-B-0-A-AAA	30470795
50	14	34	38	160	45	10	121,5	M10x1	4	30464605	10083403	10083269	MHC-HSK-A050-14-160-B-0-A-AAA	30470803
50	16	38	41,5	95	48	10	61	M12x1	4	30386546	10083381	10083269	MHC-HSK-A050-16-095-B-0-A-AAA	30386450
50	16	38	-	120	48	10	94	M12x1	4	30464598	10083404	10083269	MHC-HSK-A050-16-120-B-0-A-AAA	30470796
50	16	38	-	160	48	10	134	M12x1	4	30464606	10083404	10083269	MHC-HSK-A050-16-160-B-0-A-AAA	30470804
50	18	40	41,5	95	48	10	62,5	M12x1	4	30386547	10083382	10083269	MHC-HSK-A050-18-095-B-0-A-AAA	30386451
50	18	40	-	120	48	10	94	M12x1	4	30464599	10083405	10083269	MHC-HSK-A050-18-120-B-0-A-AAA	30470797
50	18	40	-	160	48	10	134	M12x1	4	30464607	10083405	10083269	MHC-HSK-A050-18-160-B-0-A-AAA	30470805

1-channel system MQL hydraulic chucks HydroChuck | Available on request

HSK-A	Dimensions							G	sw	Components			Specification	Order No.
	d ₁	d ₂	d ₃	l ₁	l ₂	l ₃	l ₄			BDY	LS	CU		
50	20	42	55	100	50	10	42	M16x1	4	30386548	10083383	10083269	MHC-HSK-A050-20-100-B-0-A-AAA	30386452
50	20	42	-	120	50	10	94	M16x1	4	30464600	10083406	10083269	MHC-HSK-A050-20-120-B-0-A-AAA	30470798
50	20	42	-	160	50	10	134	M16x1	4	30464608	10083406	10083269	MHC-HSK-A050-20-160-B-0-A-AAA	30470806
63	6	26	45	80	36	10	37	M10x1	4	30386549	30383941	10083270	MHC-HSK-A063-06-080-B-0-A-AAA	30386453
63	6	26	38	120	36	10	78	M5	2	30464609	30383945	10083270	MHC-HSK-A063-06-120-B-0-A-AAA	30470808
63	6	26	38	160	36	10	118	M5	2	30464617	30383945	10083270	MHC-HSK-A063-06-160-B-0-A-AAA	30470816
63	6	30	38	200	36	10	155	M5	2	30464627	30383945	10083270	MHC-HSK-A063-06-200-B-0-A-AAA	30470826
63	8	28	45	80	36	10	38	M10x1	4	30386550	10083384	10083270	MHC-HSK-A063-08-080-B-0-A-AAA	30386454
63	8	28	38	120	36	10	79	M7	3	30464610	10083394	10083270	MHC-HSK-A063-08-120-B-0-A-AAA	30470809
63	8	28	38	160	36	10	118	M7	3	30464618	10083394	10083270	MHC-HSK-A063-08-160-B-0-A-AAA	30470817
63	8	32	38	200	36	10	156	M7	3	30464628	10083394	10083270	MHC-HSK-A063-08-200-B-0-A-AAA	30470827
63	10	30	45	85	40	10	44	M10x1	4	30386551	10083385	10083270	MHC-HSK-A063-10-085-B-0-A-AAA	30386455
63	10	30	40	120	40	10	79	M8x1	4	30464611	10083401	10083270	MHC-HSK-A063-10-120-B-0-A-AAA	30470810
63	10	30	40	160	40	10	115	M8x1	4	30464619	10083401	10083270	MHC-HSK-A063-10-160-B-0-A-AAA	30470818
63	10	31	40	200	40	10	155	M8x1	4	30464629	10083401	10083270	MHC-HSK-A063-10-200-B-0-A-AAA	30470828
63	12	32	45	90	45	10	49	M10x1	5	30386552	10083386	10083270	MHC-HSK-A063-12-090-B-0-A-AAA	30386456
63	12	32	40	120	45	10	51	M10x1	5	30464612	10083409	10083270	MHC-HSK-A063-12-120-B-0-A-AAA	30470811
63	12	32	40	160	45	10	121	M10x1	5	30464620	10083409	10083270	MHC-HSK-A063-12-160-B-0-A-AAA	30470819
63	12	32	40	200	45	10	161	M10x1	5	30464630	10083409	10083270	MHC-HSK-A063-12-200-B-0-A-AAA	30470829
63	14	34	45	90	45	10	50	M10x1	5	30386553	10083387	10083270	MHC-HSK-A063-14-090-B-0-A-AAA	30386457
63	14	34	40	120	45	10	81	M10x1	5	30464613	10083410	10083270	MHC-HSK-A063-14-120-B-0-A-AAA	30470812
63	14	34	40	160	45	10	121	M10x1	5	30464621	10083410	10083270	MHC-HSK-A063-14-160-B-0-A-AAA	30470820
63	14	34	40	200	45	10	161	M10x1	5	30464631	10083410	10083270	MHC-HSK-A063-14-200-B-0-A-AAA	30470830
63	16	38	45	95	48	10	56	M12x1	5	30386554	10083388	10083270	MHC-HSK-A063-16-095-B-0-A-AAA	30386458
63	16	38	-	120	48	10	91	M12x1	5	30464614	10083411	10083270	MHC-HSK-A063-16-120-B-0-A-AAA	30470813
63	16	38	-	160	48	10	131	M12x1	5	30464622	10083411	10083270	MHC-HSK-A063-16-160-B-0-A-AAA	30470821
63	16	38	-	200	48	10	171	M12x1	5	30464632	10083411	10083270	MHC-HSK-A063-16-200-B-0-A-AAA	30470831
63	18	40	45	95	48	10	56	M12x1	5	30386555	10083389	10083270	MHC-HSK-A063-18-095-B-0-A-AAA	30386459
63	18	40	-	120	48	10	89	M12x1	5	30464615	10083412	10083270	MHC-HSK-A063-18-120-B-0-A-AAA	30470814
63	18	40	-	160	48	10	129	M12x1	5	30464623	10083412	10083270	MHC-HSK-A063-18-160-B-0-A-AAA	30470822
63	18	40	-	200	48	10	169	M12x1	5	30464633	10083412	10083270	MHC-HSK-A063-18-200-B-0-A-AAA	30470832
63	20	42	50	100	50	10	61	M16x1	5	30386556	10083390	10083270	MHC-HSK-A063-20-100-B-0-A-AAA	30386460
63	20	42	-	120	50	10	89	M16x1	5	30464616	10083413	10083270	MHC-HSK-A063-20-120-B-0-A-AAA	30470815
63	20	42	-	160	50	10	129	M16x1	5	30464624	10083413	10083270	MHC-HSK-A063-20-160-B-0-A-AAA	30470823
63	20	42	-	200	50	10	169	M16x1	5	30464634	10083413	10083270	MHC-HSK-A063-20-200-B-0-A-AAA	30470833
63	25	57	-	115	56	10	89	M16x1	5	30386557	10083391	10083270	MHC-HSK-A063-25-115-B-0-A-AAA	30386461
63	25	57	-	160	56	10	134	M16x1	5	30464625	10083414	10083270	MHC-HSK-A063-25-160-B-0-A-AAA	30470824
63	25	57	-	200	56	10	174	M16x1	5	30464635	10083414	10083270	MHC-HSK-A063-25-200-B-0-A-AAA	30470834
63	32	63	-	120	60	10	94	M16x1	5	30386558	10083392	10083270	MHC-HSK-A063-32-120-B-0-A-AAA	30386462
63	32	63	-	160	60	10	134	M16x1	5	30464626	10083415	10083270	MHC-HSK-A063-32-160-B-0-A-AAA	30470825
63	32	63	-	200	60	10	174	M16x1	5	30464636	10083415	10083270	MHC-HSK-A063-32-200-B-0-A-AAA	30470835
100	6	26	45	85	36	10	37	M10x1	4	30386569	30383941	10083272	MHC-HSK-A100-06-085-B-0-A-AAA	30386810
100	6	26	38	120	36	10	74	M5	2	30464665	30383945	10083272	MHC-HSK-A100-06-120-B-0-A-AAA	30470864
100	6	26	38	160	36	10	114	M5	2	30464673	30383945	10083272	MHC-HSK-A100-06-160-B-0-A-AAA	30470872
100	6	30	38	200	36	10	155	M5	2	30464683	30383945	10083272	MHC-HSK-A100-06-200-B-0-A-AAA	30470882
100	8	28	45	85	36	10	37	M10x1	4	30386570	10083384	10083272	MHC-HSK-A100-08-085-B-0-A-AAA	30386812
100	8	28	38	120	36	10	74	M7	3	30464666	10083394	10083272	MHC-HSK-A100-08-120-B-0-A-AAA	30470865
100	8	28	38	160	36	10	114	M7	3	30464674	10083394	10083272	MHC-HSK-A100-08-160-B-0-A-AAA	30470873
100	8	32	38	200	36	10	156	M7	3	30464684	10083394	10083272	MHC-HSK-A100-08-200-B-0-A-AAA	30470883
100	10	30	45	90	40	10	43	M10x1	4	30386571	10083385	10083272	MHC-HSK-A100-10-090-B-0-A-AAA	30386813
100	10	30	40	120	40	10	75	M8x1	4	30464667	10083401	10083272	MHC-HSK-A100-10-120-B-0-A-AAA	30470866
100	10	30	40	160	40	10	115	M8x1	4	30464675	10083401	10083272	MHC-HSK-A100-10-160-B-0-A-AAA	30470874
100	10	31	40	200	40	10	155	M8x1	4	30464685	10083401	10083272	MHC-HSK-A100-10-200-B-0-A-AAA	30470884
100	12	32	45	95	45	10	49	M10x1	5	30386572	10083386	10083272	MHC-HSK-A100-12-095-B-0-A-AAA	30386814
100	12	32	40	120	45	10	75	M10x1	5	30464668	10083409	10083272	MHC-HSK-A100-12-120-B-0-A-AAA	30470867
100	12	32	40	160	45	10	115	M10x1	5	30464676	10083409	10083272	MHC-HSK-A100-12-160-B-0-A-AAA	30470875
100	12	32	40	200	45	10	155	M10x1	5	30464686	10083409	10083272	MHC-HSK-A100-12-200-B-0-A-AAA	30470885

Continued on next page.

1-channel system MQL hydraulic chucks HydroChuck | Available on request

HSK-A	Dimensions							G	sw	Components			Specification	Order No.
	d ₁	d ₂	d ₃	l ₁	l ₂	l ₃	l ₄			BDY	LS	CU		
100	14	34	45	95	45	10	49	M10x1	5	30386573	10083387	10083272	MHC-HSK-A100-14-095-B-0-A-AAA	30386815
100	14	34	40	120	45	10	76	M10x1	5	30464669	10083410	10083272	MHC-HSK-A100-14-120-B-0-A-AAA	30470868
100	14	34	40	160	45	10	116	M10x1	5	30464677	10083410	10083272	MHC-HSK-A100-14-160-B-0-A-AAA	30470876
100	14	34	40	200	45	10	156	M10x1	5	30464687	10083410	10083272	MHC-HSK-A100-14-200-B-0-A-AAA	30470886
100	16	38	45	100	48	10	55	M12x1	5	30386574	10083388	10083272	MHC-HSK-A100-16-100-B-0-A-AAA	30386816
100	16	38	-	120	48	10	81	M12x1	5	30464670	10083411	10083272	MHC-HSK-A100-16-120-B-0-A-AAA	30470869
100	16	38	-	160	48	10	121	M12x1	5	30464678	10083411	10083272	MHC-HSK-A100-16-160-B-0-A-AAA	30470877
100	16	38	-	200	48	10	161	M12x1	5	30464688	10083411	10083272	MHC-HSK-A100-16-200-B-0-A-AAA	30470887
100	18	40	45	100	48	10	56	M12x1	5	30386575	10083389	10083272	MHC-HSK-A100-18-100-B-0-A-AAA	30386817
100	18	40	-	120	48	10	81	M12x1	5	30464671	10083412	10083272	MHC-HSK-A100-18-120-B-0-A-AAA	30470870
100	18	40	-	160	48	10	121	M12x1	5	30464679	10083412	10083272	MHC-HSK-A100-18-160-B-0-A-AAA	30470878
100	18	40	-	200	48	10	161	M12x1	5	30464689	10083412	10083272	MHC-HSK-A100-18-200-B-0-A-AAA	30470888
100	20	42	50	105	50	10	60	M16x1	5	30386576	10083390	10083272	MHC-HSK-A100-20-105-B-0-A-AAA	30386818
100	20	42	-	120	50	10	81	M16x1	5	30464672	10083413	10083272	MHC-HSK-A100-20-120-B-0-A-AAA	30470871
100	20	42	-	160	50	10	121	M16x1	5	30464680	10083413	10083272	MHC-HSK-A100-20-160-B-0-A-AAA	30470879
100	20	42	-	200	50	10	161	M16x1	5	30464690	10083413	10083272	MHC-HSK-A100-20-200-B-0-A-AAA	30470889
100	25	57	-	115	56	10	86	M16x1	5	30386577	10083391	10083272	MHC-HSK-A100-25-115-B-0-A-AAA	30386819
100	25	57	-	160	56	10	131	M16x1	5	30464681	10083414	10083272	MHC-HSK-A100-25-160-B-0-A-AAA	30470880
100	25	57	-	200	56	10	171	M16x1	5	30464691	10083414	10083272	MHC-HSK-A100-25-200-B-0-A-AAA	30470890
100	32	63	-	120	60	10	91	M16x1	5	30386578	10083392	10083272	MHC-HSK-A100-32-120-B-0-A-AAA	30386820
100	32	63	-	160	60	10	131	M16x1	5	30464682	10083415	10083272	MHC-HSK-A100-32-160-B-0-A-AAA	30470881
100	32	63	-	200	60	10	171	M16x1	5	30464692	10083415	10083272	MHC-HSK-A100-32-200-B-0-A-AAA	30470891

Dimensions in mm.

Use: For clamping tools with smooth cylindrical shanks according to DIN 1835 Form A, DIN 6535 Form HA as well as with recesses according to DIN 1835 Form B, E and DIN 6535 Form HB, HE directly and without reducing sleeve in the clamping diameter. The clamping diameter is designed for a shank tolerance h6.

Items included: Tool body, length adjustment screw and coolant unit as assembly.

These components can also be ordered separately. (see table)

Design: Longest tool lives and highest manufacturing quality on usage of smooth cylindrical shanks in accordance with DIN 1835 Form A and DIN 6535 Form HA.

With a projection length of 2.5 x D (max. 50 mm) radial run-out accuracy 3 µm.

On usage of cylindrical shanks with angled clamping surface (Form E and Form HE) the accuracy may be affected.

Different versions with chip available on request.

Balancing value: G 2.5 at 25,000 min⁻¹ as delivered.

1-channel system MQL shrink chucks ThermoChuck

For manual tool change, with axial tool length adjustment
Shank HSK-A in accordance with DIN 69893-1

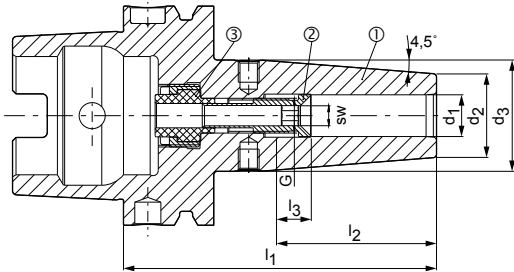

- ① Shrink chuck, HSK, MQL, tool body | BDY
- ② Length adjustment screw, MQL | LS
- ③ Coolant supply unit, MQL, manual | CU



Available on request

HSK-A	Dimensions						G	sw	Components			Specification	Order No.
	d ₁	d ₂	d ₃	l ₁	l ₂	l ₃			BDY	LS	CU		
40	6	21	27	80	36	10	M7	3	10083221	10083370	10083268	MTC-HSK-A040-06-080-B-0-A-AAA	30180001
40	8	21	27	80	36	10	M7	3	10083222	10083371	10083268	MTC-HSK-A040-08-080-B-0-A-AAA	30180002
40	10	24	32	80	40	10	M8x1	3	10083223	10083372	10083268	MTC-HSK-A040-10-080-B-0-A-AAA	30180003
40	12	24	32	90	45	10	M10x1	3	10083224	10083373	10083268	MTC-HSK-A040-12-090-B-0-A-AAA	30180004
40	14	27	34	90	45	10	M10x1	3	10083225	10083374	10083268	MTC-HSK-A040-14-090-B-0-A-AAA	30180005
40	16	27	34	90	48	10	M12x1	3	10083226	10083375	10083268	MTC-HSK-A040-16-090-B-0-A-AAA	30180006
50	6	21	27	80	36	10	M8x1	4	10083227	10083376	10083269	MTC-HSK-A050-06-080-B-0-A-AAA	30180007
50	8	21	27	80	36	10	M8x1	4	10083228	10083377	10083269	MTC-HSK-A050-08-080-B-0-A-AAA	30180008
50	10	24	32	85	40	10	M8x1	4	10083229	10083378	10083269	MTC-HSK-A050-10-085-B-0-A-AAA	30180009
50	12	24	32	90	45	10	M10x1	4	10083230	10083379	10083269	MTC-HSK-A050-12-090-B-0-A-AAA	30180010
50	14	27	34	90	45	10	M10x1	4	10083231	10083380	10083269	MTC-HSK-A050-14-090-B-0-A-AAA	30180011
50	16	27	34	95	48	10	M12x1	4	10083232	10083381	10083269	MTC-HSK-A050-16-095-B-0-A-AAA	30180012
50	18	33	42	95	48	10	M12x1	4	10083233	10083382	10083269	MTC-HSK-A050-18-095-B-0-A-AAA	30180013
50	20	33	42	100	50	10	M16x1	4	10083234	10083383	10083269	MTC-HSK-A050-20-100-B-0-A-AAA	30180014
63	6	21	27	80	36	10	M10x1	4	10083235	30383941	10083270	MTC-HSK-A063-06-080-B-0-A-AAA	30380806
63	6	21	27	120	36	10	M5	2	30386128	30383945	10083270	MTC-HSK-A063-06-120-B-0-A-AAA	30386041
63	6	21	27	160	36	10	M5	2	30386130	30383945	10083270	MTC-HSK-A063-06-160-B-0-A-AAA	30386044
63	6	21	27	200	36	10	M5	2	30386132	30383945	10083270	MTC-HSK-A063-06-200-B-0-A-AAA	30386047
63	8	21	27	80	36	10	M10x1	4	10083236	10083384	10083270	MTC-HSK-A063-08-080-B-0-A-AAA	30380807
63	8	21	27	120	36	10	M7	3	30386129	10083394	10083270	MTC-HSK-A063-08-120-B-0-A-AAA	30386042
63	8	21	27	160	36	10	M7	3	30386131	10083394	10083270	MTC-HSK-A063-08-160-B-0-A-AAA	30386045
63	8	21	27	200	36	10	M7	3	30386133	10083394	10083270	MTC-HSK-A063-08-200-B-0-A-AAA	30386048
63	10	24	32	85	40	10	M10x1	4	10083237	10083385	10083270	MTC-HSK-A063-10-085-B-0-A-AAA	30380808
63	10	24	32	120	40	10	M8x1	4	30386800	10083401	10083270	MTC-HSK-A063-10-120-B-0-A-AAA	30386043
63	10	24	32	160	40	10	M8x1	4	30386802	10083401	10083270	MTC-HSK-A063-10-160-B-0-A-AAA	30386046
63	10	24	32	200	40	10	M8x1	4	30386134	10083401	10083270	MTC-HSK-A063-10-200-B-0-A-AAA	30386049
63	12	24	32	90	45	10	M10x1	5	10083238	10083386	10083270	MTC-HSK-A063-12-090-B-0-A-AAA	30380809
63	12	24	32	120	45	10	M10x1	5	10096023	10083409	10083270	MTC-HSK-A063-12-120-B-0-A-AAA	30340365
63	12	24	32	160	45	10	M10x1	5	30197953	10083409	10083270	MTC-HSK-A063-12-160-B-0-A-AAA	30197954
63	12	24	32	200	45	10	M10x1	5	10107285	10083409	10083270	MTC-HSK-A063-12-200-B-0-A-AAA	30340376
63	14	27	34	90	45	10	M10x1	5	10083239	10083387	10083270	MTC-HSK-A063-14-090-B-0-A-AAA	30380810
63	14	27	34	120	45	10	M10x1	5	30192712	10083410	10083270	MTC-HSK-A063-14-120-B-0-A-AAA	30192710
63	14	27	34	160	45	10	M10x1	5	10096025	10083410	10083270	MTC-HSK-A063-14-160-B-0-A-AAA	30340369
63	14	27	34	200	45	10	M10x1	5	10096026	10083410	10083270	MTC-HSK-A063-14-200-B-0-A-AAA	30340377
63	16	27	34	95	48	10	M12x1	5	10083240	10083388	10083270	MTC-HSK-A063-16-095-B-0-A-AAA	30380811
63	16	27	34	120	48	10	M12x1	5	10107287	10083411	10083270	MTC-HSK-A063-16-120-B-0-A-AAA	30340366
63	16	27	34	160	48	10	M12x1	5	10107288	10083411	10083270	MTC-HSK-A063-16-160-B-0-A-AAA	30340370
63	16	27	34	200	48	10	M12x1	5	10107289	10083411	10083270	MTC-HSK-A063-16-200-B-0-A-AAA	30340378
63	18	33	42	95	48	10	M12x1	5	10083241	10083389	10083270	MTC-HSK-A063-18-095-B-0-A-AAA	30380812

1-channel system MQL shrink chucks ThermoChuck | Available on request

HSK-A	Dimensions						G	sw	Components			Specification	Order No.
	d ₁	d ₂	d ₃	l ₁	l ₂	l ₃			BDY	LS	CU		
63	18	33	42	120	48	10	M12x1	5	10107292	10083412	10083270	MTC-HSK-A063-18-120-B-0-A-AAA	30340367
63	18	33	42	160	48	10	M12x1	5	10096027	10083412	10083270	MTC-HSK-A063-18-160-B-0-A-AAA	30340371
63	18	33	42	200	48	10	M12x1	5	10107293	10083412	10083270	MTC-HSK-A063-18-200-B-0-A-AAA	30340379
63	20	33	42	100	50	10	M16x1	5	10083242	10083390	10083270	MTC-HSK-A063-20-100-B-0-A-AAA	30380813
63	20	33	42	120	50	10	M16x1	5	30192716	10083413	10083270	MTC-HSK-A063-20-120-B-0-A-AAA	30192715
63	20	33	42	160	50	10	M16x1	5	10107294	10083413	10083270	MTC-HSK-A063-20-160-B-0-A-AAA	30340372
63	20	33	42	200	50	10	M16x1	5	10107295	10083413	10083270	MTC-HSK-A063-20-200-B-0-A-AAA	30340380
63	25	44	53	115	56	10	M16x1	5	10083243	10083391	10083270	MTC-HSK-A063-25-115-B-0-A-AAA	30380814
63	25	44	53	160	56	10	M16x1	5	10107296	10083414	10083270	MTC-HSK-A063-25-160-B-0-A-AAA	30340373
63	25	44	53	200	56	10	M16x1	5	10107297	10083414	10083270	MTC-HSK-A063-25-200-B-0-A-AAA	30340381
63	32	44	53	120	60	10	M16x1	5	10083244	10083392	10083270	MTC-HSK-A063-32-120-B-0-A-AAA	30380815
63	32	44	53	160	60	10	M16x1	5	10107298	10083415	10083270	MTC-HSK-A063-32-160-B-0-A-AAA	30340374
63	32	44	53	200	60	10	M16x1	5	10107299	10083415	10083270	MTC-HSK-A063-32-200-B-0-A-AAA	30340382
80	6	21	27	85	36	10	M10x1	4	10083245	30383941	10083271	MTC-HSK-A080-06-085-B-0-A-AAA	30380844
80	8	21	27	85	36	10	M10x1	4	10083246	10083384	10083271	MTC-HSK-A080-08-085-B-0-A-AAA	30380845
80	10	24	32	90	40	10	M10x1	4	10083247	10083385	10083271	MTC-HSK-A080-10-090-B-0-A-AAA	30380846
80	12	24	32	95	45	10	M10x1	5	10083248	10083386	10083271	MTC-HSK-A080-12-095-B-0-A-AAA	30380847
80	14	27	34	95	45	10	M10x1	5	10083249	10083387	10083271	MTC-HSK-A080-14-095-B-0-A-AAA	30380848
80	16	27	34	100	48	10	M12x1	5	10083250	10083388	10083271	MTC-HSK-A080-16-100-B-0-A-AAA	30380849
80	18	33	42	100	48	10	M12x1	5	10083251	10083389	10083271	MTC-HSK-A080-18-100-B-0-A-AAA	30380850
80	20	33	42	105	50	10	M16x1	5	10083252	10083390	10083271	MTC-HSK-A080-20-105-B-0-A-AAA	30380851
80	25	44	53	115	56	10	M16x1	5	10083253	10083391	10083271	MTC-HSK-A080-25-115-B-0-A-AAA	30380852
80	32	44	53	120	60	10	M16x1	5	10083254	10083392	10083271	MTC-HSK-A080-32-120-B-0-A-AAA	30380853
100	6	21	27	85	36	10	M10x1	4	10083255	30383941	10083272	MTC-HSK-A100-06-085-B-0-A-AAA	30380882
100	6	21	27	120	36	10	M5	2	30386144	30383945	10083272	MTC-HSK-A100-06-120-B-0-A-AAA	30386059
100	6	21	27	160	36	10	M5	2	30386147	30383945	10083272	MTC-HSK-A100-06-160-B-0-A-AAA	30386062
100	6	21	27	200	36	10	M5	2	30386150	30383945	10083272	MTC-HSK-A100-06-200-B-0-A-AAA	30386065
100	8	21	27	85	36	10	M10x1	4	10083256	10083384	10083272	MTC-HSK-A100-08-085-B-0-A-AAA	30380883
100	8	21	27	120	36	10	M7	3	30386145	10083394	10083272	MTC-HSK-A100-08-120-B-0-A-AAA	30386060
100	8	21	27	160	36	10	M7	3	30386148	10083394	10083272	MTC-HSK-A100-08-160-B-0-A-AAA	30386063
100	8	21	27	200	36	10	M7	3	30386151	10083394	10083272	MTC-HSK-A100-08-200-B-0-A-AAA	30386066
100	10	24	32	90	40	10	M10x1	4	10083257	10083385	10083272	MTC-HSK-A100-10-090-B-0-A-AAA	30380884
100	10	24	32	120	40	10	M8x1	4	30386146	10083401	10083272	MTC-HSK-A100-10-120-B-0-A-AAA	30386061
100	10	24	32	160	40	10	M8x1	4	30386149	10083401	10083272	MTC-HSK-A100-10-160-B-0-A-AAA	30386064
100	10	24	32	200	40	10	M8x1	4	30386152	10083401	10083272	MTC-HSK-A100-10-200-B-0-A-AAA	30386067
100	12	24	32	95	45	10	M10x1	5	10083258	10083386	10083272	MTC-HSK-A100-12-095-B-0-A-AAA	30380885
100	12	24	32	120	45	10	M10x1	5	30253151	10083409	10083272	MTC-HSK-A100-12-120-B-0-A-AAA	30480245
100	12	24	32	160	45	10	M10x1	5	30302825	10083409	10083272	MTC-HSK-A100-12-160-B-0-A-AAA	30480250
100	12	24	32	200	45	10	M10x1	5	30253152	10083409	10083272	MTC-HSK-A100-12-200-B-0-A-AAA	30480257
100	14	27	34	95	45	10	M10x1	5	10083259	10083387	10083272	MTC-HSK-A100-14-095-B-0-A-AAA	30380886
100	14	27	34	120	45	10	M10x1	5	30254306	10083410	10083272	MTC-HSK-A100-14-120-B-0-A-AAA	30480246
100	14	27	34	160	45	10	M10x1	5	30302826	10083410	10083272	MTC-HSK-A100-14-160-B-0-A-AAA	30480251
100	14	27	34	200	45	10	M10x1	5	30303050	10083410	10083272	MTC-HSK-A100-14-200-B-0-A-AAA	30480258
100	16	27	34	100	48	10	M12x1	5	10083260	10083388	10083272	MTC-HSK-A100-16-100-B-0-A-AAA	30380887
100	16	27	34	120	48	10	M12x1	5	30302821	10083411	10083272	MTC-HSK-A100-16-120-B-0-A-AAA	30480247
100	16	27	34	160	48	10	M12x1	5	30302827	10083411	10083272	MTC-HSK-A100-16-160-B-0-A-AAA	30480252
100	16	27	34	200	48	10	M12x1	5	30302831	10083411	10083272	MTC-HSK-A100-16-200-B-0-A-AAA	30480259
100	18	33	42	100	48	10	M12x1	5	10083261	10083389	10083272	MTC-HSK-A100-18-100-B-0-A-AAA	30380888
100	18	33	42	120	48	10	M12x1	5	30253155	10083412	10083272	MTC-HSK-A100-18-120-B-0-A-AAA	30480248
100	18	33	42	160	48	10	M12x1	5	10096879	10083412	10083272	MTC-HSK-A100-18-160-B-0-A-AAA	30480253
100	18	33	42	200	48	10	M12x1	5	10107134	10083412	10083272	MTC-HSK-A100-18-200-B-0-A-AAA	30480260
100	20	33	42	105	50	10	M16x1	5	10083262	10083390	10083272	MTC-HSK-A100-20-105-B-0-A-AAA	30380889
100	20	33	42	120	50	10	M16x1	5	30302822	10083413	10083272	MTC-HSK-A100-20-120-B-0-A-AAA	30480249
100	20	33	42	160	50	10	M16x1	5	10096880	10083413	10083272	MTC-HSK-A100-20-160-B-0-A-AAA	30480254
100	20	33	42	200	50	10	M16x1	5	30302832	10083413	10083272	MTC-HSK-A100-20-200-B-0-A-AAA	30480261
100	25	44	53	115	56	10	M16x1	5	10083263	10083391	10083272	MTC-HSK-A100-25-115-B-0-A-AAA	30380890
100	25	44	53	160	56	10	M16x1	5	30258455	10083414	10083272	MTC-HSK-A100-25-160-B-0-A-AAA	30480255

1-channel system MQL shrink chucks ThermoChuck | Available on request

HSK-A	Dimensions						G	sw	Components			Specification	Order No.
	d ₁	d ₂	d ₃	l ₁	l ₂	l ₃			BDY	LS	CU		
100	25	44	53	200	56	10	M16x1	5	30302833	10083414	10083272	MTC-HSK-A100-25-200-B-0-A-AAA	30480262
100	32	44	53	120	60	10	M16x1	5	10083264	10083392	10083272	MTC-HSK-A100-32-120-B-0-A-AAA	30380891
100	32	44	53	160	60	10	M16x1	5	30303048	10083415	10083272	MTC-HSK-A100-32-160-B-0-A-AAA	30480256
100	32	44	53	200	60	10	M16x1	5	30302834	10083415	10083272	MTC-HSK-A100-32-200-B-0-A-AAA	30480263

Dimensions in mm.

Items included: Tool body, length adjustment screw and coolant unit as assembly.

These components can also be ordered separately (see table).

Design: Permissible run-out deviation on the hollow taper shank in relation to the clamping diameter $d_1 = 3 \mu\text{m}$. The clamping diameter is designed for a shank tolerance of h6.

Different versions with chip available on request.

Balancing value: G 2.5 at $25,000 \text{ min}^{-1}$ as delivered.





CHUCKS FOR MQL 2-CHANNEL SYSTEM



Selection system

Chucks MQL 2-channel system _____ 24

Automatic tool change



Hydraulic chucks HydroChuck with axial length adjustment _____ 34



Shrink chucks ThermoChuck _____ 42

Selection of chucks MQL 2-channel system

On the selection of the chucks for the MQL 2-channel system, it is imperative attention is paid to ensuring the cross-sections of the MQL connections (length adjustment screw and coolant supply unit) match the sum of the cross-sections of all coolant outlets on the tool.

The correct ratio of inlet cross-section A_{IN} to the outlet cross-section A_{OUT} is ensured by the so-called MQL ratio. The MQL ratio should be a maximum of 4 and should not be less than 1.

$$\text{MQL ratio} = \frac{A_{IN}}{A_{OUT}} \qquad 1 \leq \text{MQL ratio} \leq 4$$

A_{IN} : Defined by the bore diameter on the length adjustment screw

A_{OUT} : Defined by the sum of the cross-sections of all coolant outlets on the tool

NOTE

It is necessary to maintain the MQL ratio for the following reasons:

- To ensure a continuous supply of oil
- Transport the entire volume of oil provided by the 2-channel system
- Short reaction times (time from switching on the oil supply to the outlet of the oil-air mixture from the coolant outlets on the tool)

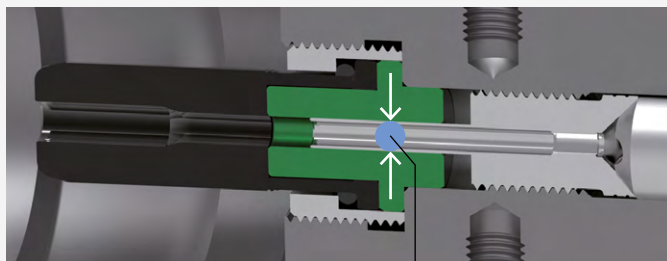
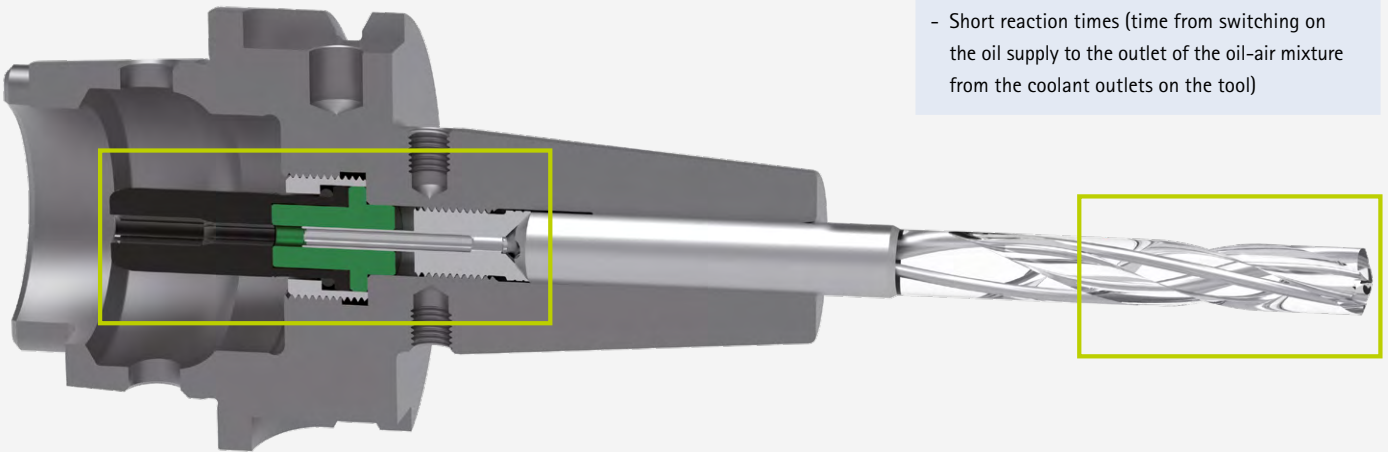

A_{IN}

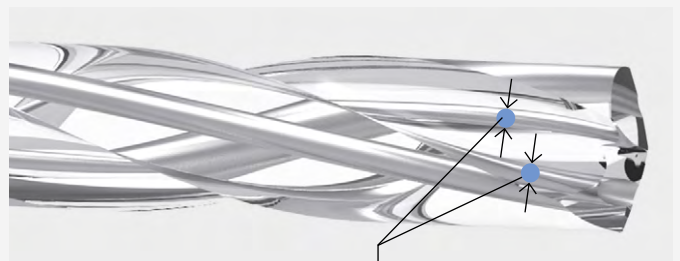

Information on MAPAL drawing for the tool:
 $A_{OUT} = A_{OUT1} + A_{OUT2}$

Due to the need to maintain the MQL ratio, up to three different coolant supply units with the related length adjustment screw can be selected for one shank diameter. To keep, nevertheless the number of variants as low as possible, a Standard or preferred series is defined. Only if the MQL ratio cannot be maintained with this Standard series

is usage made of the Semi-standard 1 as the next smaller variant. Should it also not be possible to maintain the MQL ratio with this series, Semi-standard 2 is used.

For standard MQL tools, for example solid carbide drills, use the selection aid with examples on the following pages.

Definition of the variants Standard, Semi-standard 1 and Semi-standard 2

Cross-sectional area A_{IN} , inside diameter d_i and wrench size for the length adjustment screw as a function of the shank diameter and the HSK size

HSK size	Shank \varnothing	Standard			Semi-standard 1			Semi-standard 2		
		A_{IN} [mm ²]	d_i [mm]	sw	A_{IN} [mm ²]	d_i [mm]	sw	A_{IN} [mm ²]	d_i [mm]	sw
32	06 – 12	4,52	2,40	2	1,54	1,40	1,5	–	–	–
40 - 100	06 – 10	4,52	2,40	2	1,54	1,40	1,5	–	–	–
	12 – 18	9,90	3,55	3	4,52	2,40	2	1,54	1,40	1,5
	20 – 32	17,35	4,70	4	9,90	3,55	3	4,52	2,40	2

Procedure for the selection of the variants Standard, Semi-standard 1 and Semi-standard 2
 Inlet cross-sections A_{IN} can be taken from the above table for the calculation of the MQL ratio.

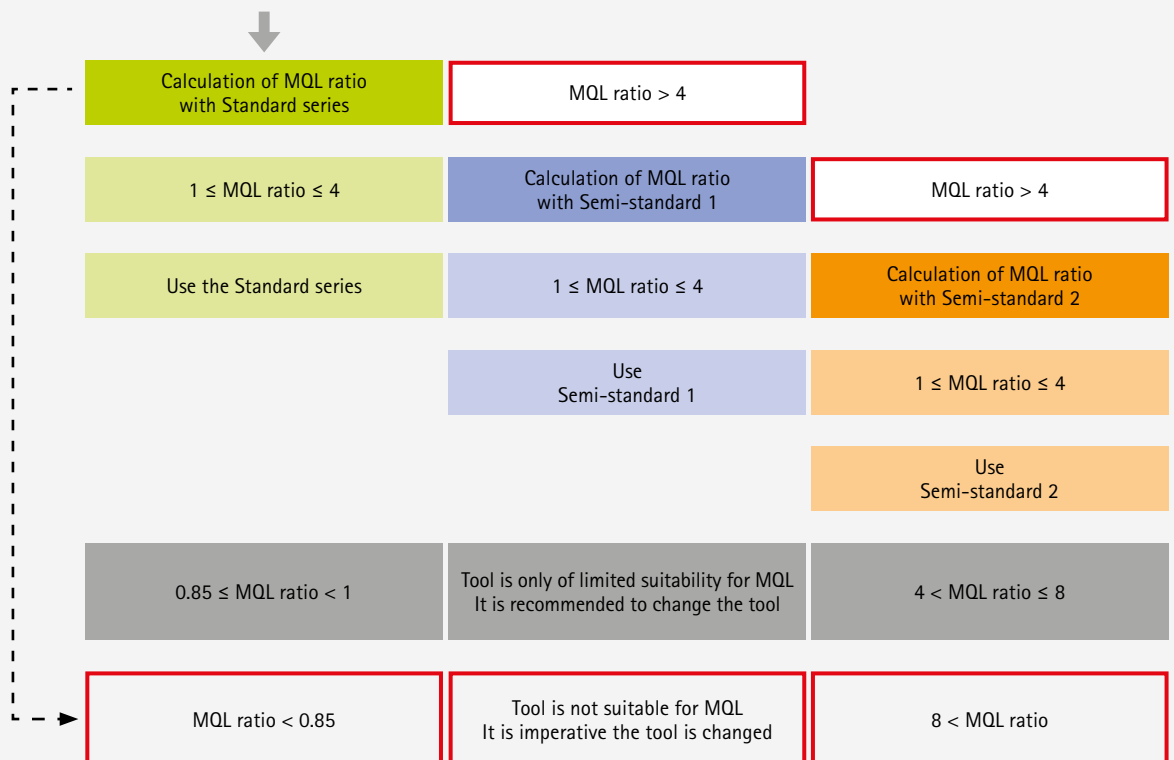

Selection system example for determining the variant for 2-channel systems

The following selection aids can be used to select the chuck more quickly and straightforwardly. The procedure is defined in the following.

- ① Selection of the table to suit the shank diameter
- ② Selection of the range based on the number and diameter of the cooling channels
- ③ Determination of the series via colour coding

Example 1

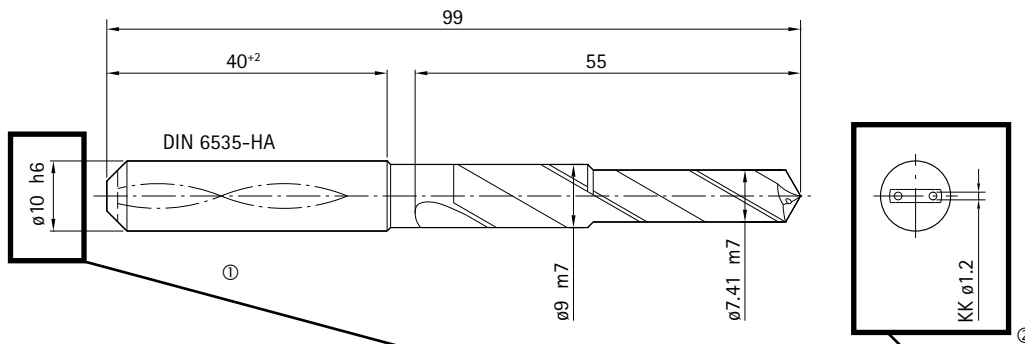

Cooling channel ø		0,3		0,4		0,5		0,6		0,7		0,8		0,9		1,0		1,1		1,2		1,3		1,4	
		A _{qur} [mm ²]	MQL ratio	A _{qur} [mm ²]	MQL ratio	A _{qur} [mm ²]	MQL ratio	A _{qur} [mm ²]	MQL ratio	A _{qur} [mm ²]	MQL ratio	A _{qur} [mm ²]	MQL ratio	A _{qur} [mm ²]	MQL ratio	A _{qur} [mm ²]	MQL ratio	A _{qur} [mm ²]	MQL ratio	A _{qur} [mm ²]	MQL ratio	A _{qur} [mm ²]	MQL ratio	A _{qur} [mm ²]	MQL ratio
Number of cooling channels	1	0,07	21,78	0,13	12,25	0,20	7,84	0,28	5,44	0,38	4,00	0,50	3,06	0,64	2,42	0,79	1,96	0,95	1,62	1,13	4,00	1,33	3,41	1,54	2,94
	2	0,14	10,89	0,25	6,13	0,39	3,92	0,57	2,72	0,77	2,00	1,01	1,53	1,27	3,56	1,57	2,88	1,90	2,38	2,26	2,00	2,65	1,70	3,08	1,47
	3	0,21	7,26	0,38	4,08	0,59	2,61	0,85	1,81	1,15	3,92	1,51	3,00	1,91	2,37	2,36	1,92	2,85	1,59	3,39	1,33	3,98	1,14	4,62	0,98
	4	0,28	5,44	0,50	3,06	0,79	1,96	1,13	4,00	1,54	2,94	2,01	2,25	2,54	1,78	3,14	1,44	3,80	1,19	4,52	1,00	5,31	0,85	6,16	
	5	0,35	4,36	0,63	2,45	0,98	1,57	1,41	3,20	1,92	2,35	2,51	1,80	3,18	1,42	3,93	1,15	4,75	0,85	5,65		6,64		7,70	
	6	0,42	3,63	0,75	2,04	1,18	3,84	1,70	2,67	2,31	1,96	3,02	1,50	3,82	1,19	4,71	0,96	5,70		6,79		7,96		9,24	
	7	0,49	3,11	0,88	1,75	1,37	3,29	1,98	2,29	2,69	1,68	3,52	1,29	4,45	1,02	5,50		6,65		7,92		9,29		10,78	
	8	0,57	2,72	1,01	1,53	1,57	2,88	2,26	2,00	3,08	1,47	4,02	1,13	5,09	0,88	6,28		7,60		9,05		10,62		12,32	

Variante*	HSK-A	Baumaße							G	A _{IN}	sw	Komponenten			Spezifikation	Bestell-Nr.
		d ₁	d ₂	d ₃	l ₁	l ₂	l ₃	l ₄				BDY	LS	CU		
	63	6	26	45	80	36	10	37	M10x1	1,54	1,5	30386549	30512784	30512203	MHC-HSK-A063-06-080-C-0-A-AAA1	30522882
	63	6	26	45	80	36	10	37	M10x1	4,52	2	30386549	30384039	30384304	MHC-HSK-A063-06-080-C-0-A-AAA2	30386278
	63	6	26	38	120	36	10	78	M5	1,54	1,5	30464609	30512804	30512203	MHC-HSK-A063-06-120-C-0-A-AAA1	30522916
	63	6	26	38	120	36	10	78	M5	4,52	2	30464609	30384040	30384304	MHC-HSK-A063-06-120-C-0-A-AAA2	30485332
	63	8	28	45	80	36	10	37,5	M10x1	1,54	1,5	30386550	30512785	30512203	MHC-HSK-A063-08-080-C-0-A-AAA1	30522883
	63	8	28	45	80	36	10	37,5	M10x1	4,52	2	30386550	30384043	30384304	MHC-HSK-A063-08-080-C-0-A-AAA2	30386279
	63	8	28	38	120	36	10	78,5	M7	1,54	1,5	30464610	30512805	30512203	MHC-HSK-A063-08-120-C-0-A-AAA1	30522917
	63	8	28	38	120	36	10	78,5	M7	4,52	2	30464610	30384044	30384304	MHC-HSK-A063-08-120-C-0-A-AAA2	30485333
	63	10	30	45	85	40	10	43,5	M10x1	1,54	1,5	30386551	30512786	30512203	MHC-HSK-A063-10-085-C-0-A-AAA1	30522884
	63	10	30	45	85	40	10	43,5	M10x1	4,52	2	30386551	30384011	30384304	MHC-HSK-A063-10-085-C-0-A-AAA2	30386280
	63	10	30	40	120	40	10	79	M8x1	1,54	1,5	30464611	30512806	30512203	MHC-HSK-A063-10-120-C-0-A-AAA1	30522918
	63	10	30	40	120	40	10	79	M8x1	4,52	2	30464611	30384012	30384304	MHC-HSK-A063-10-120-C-0-A-AAA2	30485334
	63	12	32	45	90	45	10	49	M10x1	1,54	1,5	30386552	30512791	30512203	MHC-HSK-A063-12-090-C-0-A-AAA1	30522885

Calculation of the MQL ratio taking into account the inlet cross-section A_{IN} Semi-standard 1 variant.

- ① Selection of the table to suit the shank diameter
- ② Selection of the range based on the number and diameter of the cooling channels
- ③ Determination of the series via colour coding

Example 2

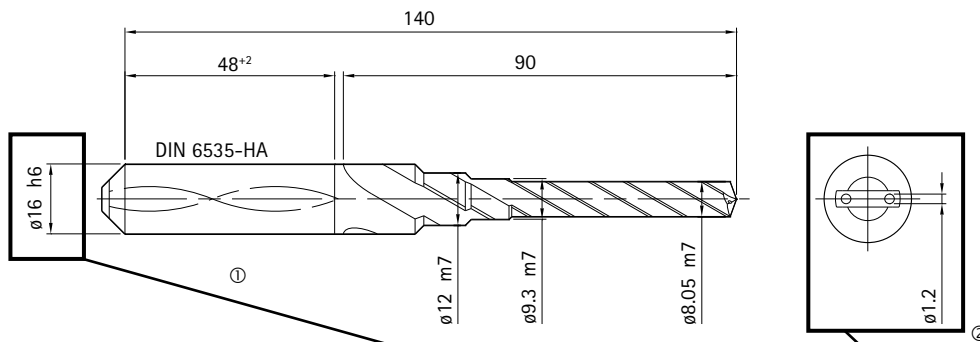

		Connection ø:		12 - 18		Standard / wrench size 3		Semi-standard 1 / wrench size 2		Semi-standard 2 / wrench size 1.5		MQL ratio with wrench size 1.5 too small and with wrench size 3 too large; permissible with limitations															
		Cooling channel ø		0,3		0,4		0,5		0,6		0,7		0,8		0,9		1,0		1,1		1,2		1,3		1,4	
Number of cooling channels		A _{cut} [mm ²]	MQL ratio	A _{cut} [mm ²]	MQL ratio	A _{cut} [mm ²]	MQL ratio	A _{cut} [mm ²]	MQL ratio	A _{cut} [mm ²]	MQL ratio	A _{cut} [mm ²]	MQL ratio	A _{cut} [mm ²]	MQL ratio	A _{cut} [mm ²]	MQL ratio	A _{cut} [mm ²]	MQL ratio	A _{cut} [mm ²]	MQL ratio	A _{cut} [mm ²]	MQL ratio	A _{cut} [mm ²]	MQL ratio	A _{cut} [mm ²]	MQL ratio
		1		0,07	21,78	0,13	12,25	0,20	7,84	0,28	5,44	0,38	4,00	0,50	3,06	0,64	2,42	0,79	1,96	0,95	1,62			1,13	4,00	1,33	3,41
2		0,14	10,89	0,25	6,13	0,39	3,92	0,57	2,72	0,77	2,00	1,01	1,53	1,27	3,56	1,57	2,88	1,90	2,38			2,26	2,00	2,65	3,73	3,08	3,21
3		0,21	7,26	0,38	4,08	0,59	2,61	0,85	1,81	1,15	3,92	1,51	3,00	1,91	2,37	2,36	1,92	2,85	3,47			3,39	2,92	3,98	2,49	4,62	2,14
4		0,28	5,44	0,50	3,06	0,79	1,96	1,13	4,00	1,54	2,94	2,01	2,25	2,54	3,89	3,14	3,15	3,80	2,60			4,52	2,19	5,31	1,86	6,16	1,61
5		0,35	4,36	0,63	2,45	0,98	1,57	1,41	3,20	1,92	2,35	2,51	3,94	3,18	3,11	3,93	2,52	4,75	2,08			5,65	1,75	6,64	1,49	7,70	1,29
6		0,42	3,63	0,75	2,04	1,18	3,84	1,70	2,67	2,31	4,29	3,02	3,28	3,82	2,59	4,71	2,10	5,70	1,74			6,79	1,46	7,96	1,24	9,24	1,07
7		0,49	3,11	0,88	1,75	1,37	3,29	1,98	2,29	2,69	3,67	3,52	2,81	4,45	2,22	5,50	1,80	6,65	1,49			7,92	1,25	9,29	1,07	10,78	0,92

Variante*	HSK-A	Baumaße						G	A _{IN}	sw	Komponenten			Spezifikation	Bestell-Nr.
		d ₁	d ₂	d ₃	l ₁	l ₂	l ₃				BDY	LS	CU		
	63	6	21	27	80	36	10	M10x1	1,54	1,5	10083235	30512784	30512203	MTC-HSK-A063-06-080-C-0-A-AAA1	30521882
	63	6	21	27	80	36	10	M10x1	4,52	2	10083235	30384039	30384304	MTC-HSK-A063-06-080-C-0-A-AAA2	30385638
	63	6	21	27	120	36	10	M5	1,54	1,5	30386128	30512804	30512203	MTC-HSK-A063-06-120-C-0-A-AAA1	30521884
	63	6	21	27	120	36	10	M5	4,52	2	30386128	30384040	30384304	MTC-HSK-A063-06-120-C-0-A-AAA2	30385658
	63	8	21	27	80	36	10	M10x1	1,54	1,5	10083236	30512785	30512203	MTC-HSK-A063-08-080-C-0-A-AAA1	30521890
	63	8	21	27	80	36	10	M10x1	4,52	2	10083236	30384043	30384304	MTC-HSK-A063-08-080-C-0-A-AAA2	30385639
	63	8	21	27	120	36	10	M7	1,54	1,5	30386129	30512805	30512203	MTC-HSK-A063-08-120-C-0-A-AAA1	30521892
	63	8	21	27	120	36	10	M7	4,52	2	30386129	30384044	30384304	MTC-HSK-A063-08-120-C-0-A-AAA2	30385659
	63	10	24	32	85	40	10	M10x1	1,54	1,5	10083237	30512786	30512203	MTC-HSK-A063-10-085-C-0-A-AAA1	30521898
	63	10	24	32	85	40	10	M10x1	4,52	2	10083237	30384011	30384304	MTC-HSK-A063-10-085-C-0-A-AAA2	30385640
	63	10	24	32	120	40	10	M8x1	1,54	1,5	30386800	30512806	30512203	MTC-HSK-A063-10-120-C-0-A-AAA1	30521900
	63	10	24	32	120	40	10	M8x1	4,52	2	30386800	30384012	30384304	MTC-HSK-A063-10-120-C-0-A-AAA2	30385660
	63	12	24	32	90	45	10	M10x1	1,54	1,5	10083238	30512791	30512203	MTC-HSK-A063-12-090-C-0-A-AAA1	30521906

Calculation of the MQL ratio taking into account the inlet cross-section A_{IN} Semi-standard 1 variant.

Selection system example for determining the variant

For 2-channel system chucks with diameter 6 - 10 mm

		Mounting diameter										6 - 10		Standard / wrench size 2									
														Semi-standard 1 / wrench size 1.5									
														MQL ratio with wrench size 1.5 too small and with wrench size 2									
		Cooling channel diameter																					
		0,3		0,4		0,5		0,6		0,7		0,8		0,9		1,0		1,1					
		A _{out} [mm ²]	MQL ratio	A _{out} [mm ²]	MQL ratio	A _{out} [mm ²]	MQL ratio	A _{out} [mm ²]	MQL ratio	A _{out} [mm ²]	MQL ratio	A _{out} [mm ²]	MQL ratio	A _{out} [mm ²]	MQL ratio	A _{out} [mm ²]	MQL ratio	A _{out} [mm ²]	MQL ratio	A _{out} [mm ²]	MQL ratio	A _{out} [mm ²]	MQL ratio
Number of cooling channels	1	0,07	21,78	0,13	12,25	0,20	7,84	0,28	5,44	0,38	4,00	0,50	3,06	0,64	2,42	0,79	1,96	0,95	1,62				
	2	0,14	10,89	0,25	6,13	0,39	3,92	0,57	2,72	0,77	2,00	1,01	1,53	1,27	3,56	1,57	2,88	1,90	2,38				
	3	0,21	7,26	0,38	4,08	0,59	2,61	0,85	1,81	1,15	3,92	1,51	3,00	1,91	2,37	2,36	1,92	2,85	1,59				
	4	0,28	5,44	0,50	3,06	0,79	1,96	1,13	4,00	1,54	2,94	2,01	2,25	2,54	1,78	3,14	1,44	3,80	1,19				
	5	0,35	4,36	0,63	2,45	0,98	1,57	1,41	3,20	1,92	2,35	2,51	1,80	3,18	1,42	3,93	1,15	4,75	0,95				
	6	0,42	3,63	0,75	2,04	1,18	3,84	1,70	2,67	2,31	1,96	3,02	1,50	3,82	1,19	4,71	0,96	5,70					
	7	0,49	3,11	0,88	1,75	1,37	3,29	1,98	2,29	2,69	1,68	3,52	1,29	4,45	1,02	5,50		6,65					
	8	0,57	2,72	1,01	1,53	1,57	2,88	2,26	2,00	3,08	1,47	4,02	1,13	5,09	0,89	6,28		7,60					
Number of cooling channels		2,2		2,3		2,4		2,5		2,6		2,7		2,8		2,9		3,0					
		A _{out} [mm ²]	MQL ratio	A _{out} [mm ²]	MQL ratio	A _{out} [mm ²]	MQL ratio	A _{out} [mm ²]	MQL ratio	A _{out} [mm ²]	MQL ratio	A _{out} [mm ²]	MQL ratio	A _{out} [mm ²]	MQL ratio	A _{out} [mm ²]	MQL ratio	A _{out} [mm ²]	MQL ratio	A _{out} [mm ²]	MQL ratio	A _{out} [mm ²]	MQL ratio
	1	3,80	1,19	4,15	1,09	4,52	1,00	4,91	0,92	5,31		5,73		6,16		6,61		7,07					
	2	7,60		8,31		9,05		9,82		10,62		11,45		12,32		13,21		14,14					
	3	11,40		12,46		13,57		14,73		15,93		17,18		18,47		19,82		21,21					
	4	15,21		16,62		18,10		19,63		21,24		22,90		24,63		26,42		28,27					
	5	19,01		20,77		22,62		24,54		26,55		28,63		30,79		33,03		35,34					
	6	22,81		24,93		27,14		29,45		31,86		34,35		36,95		39,63		42,41					
	7	26,61		29,08		31,67		34,36		37,17		40,08		43,10		46,24		49,48					
8	30,41		33,24		36,19		39,27		42,47		45,80		49,26		52,84		56,55						

too large permissible with limitations

1,2		1,3		1,4		1,5		1,6		1,7		1,8		1,9		2,0		2,1	
A _{out} [mm ²]	MQL ratio	A _{out} [mm ²]	MQL ratio	A _{out} [mm ²]	MQL ratio	A _{out} [mm ²]	MQL ratio	A _{out} [mm ²]	MQL ratio	A _{out} [mm ²]	MQL ratio	A _{out} [mm ²]	MQL ratio	A _{out} [mm ²]	MQL ratio	A _{out} [mm ²]	MQL ratio	A _{out} [mm ²]	MQL ratio
1,13	4,00	1,33	3,41	1,54	2,94	1,77	2,56	2,01	2,25	2,27	1,99	2,54	1,78	2,84	1,60	3,14	1,44	3,46	1,31
2,26	2,00	2,65	1,70	3,08	1,47	3,53	1,28	4,02	1,13	4,54	1,00	5,09	0,89	5,67		6,28		6,93	
3,39	1,33	3,98	1,14	4,62	0,98	5,30		6,03		6,81		7,63		8,51		9,42		10,39	
4,52	1,00	5,31	0,85	6,16		7,07		8,04		9,08		10,18		11,34		12,57		13,85	
5,65		6,64		7,70		8,84		10,05		11,35		12,72		14,18		15,71		17,32	
6,79		7,96		9,24		10,60		12,06		13,62		15,27		17,01		18,85		20,78	
7,92		9,29		10,78		12,37		14,07		15,89		17,81		19,85		21,99		24,25	
9,05		10,62		12,32		14,14		16,08		18,16		20,36		22,68		25,13		27,71	
3,1		3,2		3,3		3,4		3,5		3,6		3,7		3,8		3,9		4,0	
A _{out} [mm ²]	MQL ratio	A _{out} [mm ²]	MQL ratio	A _{out} [mm ²]	MQL ratio	A _{out} [mm ²]	MQL ratio	A _{out} [mm ²]	MQL ratio	A _{out} [mm ²]	MQL ratio	A _{out} [mm ²]	MQL ratio	A _{out} [mm ²]	MQL ratio	A _{out} [mm ²]	MQL ratio	A _{out} [mm ²]	MQL ratio
7,55		8,04		8,55		9,08		9,62		10,18		10,75		11,34		11,95		12,57	
15,10		16,08		17,11		18,16		19,24		20,36		21,50		22,68		23,89		25,13	
22,64		24,13		25,66		27,24		28,86		30,54		32,26		34,02		35,84		37,70	
30,19		32,17		34,21		36,32		38,48		40,72		43,01		45,36		47,78		50,27	
37,74		40,21		42,76		45,40		48,11		50,89		53,76		56,71		59,73		62,83	
45,29		48,25		51,32		54,48		57,73		61,07		64,51		68,05		71,68		75,40	
52,83		56,30		59,87		63,55		67,35		71,25		75,26		79,39		83,62		87,96	
60,38		64,34		68,42		72,63		76,97		81,43		86,02		90,73		95,57		100,53	



Taking into account the MQL ratio to be maintained for the 2-channel system, the tool is not suitable for MQL. It is imperative the tool is changed.

Selection system example for determining the variant

For 2-channel system chucks with diameter 12 - 18 mm

		Mounting diameter																		12 - 18	
																				Standard / wrench size 3	
																				Semi-standard 1 / wrench size 2	
		Cooling channel diameter																		Semi-standard 2 / wrench size 1.5	
																				MQL ratio with wrench size 1.5 too small and with wrench size 3	
		0,3		0,4		0,5		0,6		0,7		0,8		0,9		1,0		1,1			
		A _{out} [mm ²]	MQL ratio	A _{out} [mm ²]	MQL ratio	A _{out} [mm ²]	MQL ratio	A _{out} [mm ²]	MQL ratio	A _{out} [mm ²]	MQL ratio	A _{out} [mm ²]	MQL ratio	A _{out} [mm ²]	MQL ratio	A _{out} [mm ²]	MQL ratio	A _{out} [mm ²]	MQL ratio		
Number of cooling channels	1	0,07	21,78	0,13	12,25	0,20	7,84	0,28	5,44	0,38	4,00	0,50	3,06	0,64	2,42	0,79	1,96	0,95	1,62		
	2	0,14	10,89	0,25	6,13	0,39	3,92	0,57	2,72	0,77	2,00	1,01	1,53	1,27	3,56	1,57	2,88	1,90	2,38		
	3	0,21	7,26	0,38	4,08	0,59	2,61	0,85	1,81	1,15	3,92	1,51	3,00	1,91	2,37	2,36	1,92	2,85	3,47		
	4	0,28	5,44	0,50	3,06	0,79	1,96	1,13	4,00	1,54	2,94	2,01	2,25	2,54	3,89	3,14	3,15	3,80	2,60		
	5	0,35	4,36	0,63	2,45	0,98	1,57	1,41	3,20	1,92	2,35	2,51	3,94	3,18	3,11	3,93	2,52	4,75	2,08		
	6	0,42	3,63	0,75	2,04	1,18	3,84	1,70	2,67	2,31	4,29	3,02	3,28	3,82	2,59	4,71	2,10	5,70	1,74		
	7	0,49	3,11	0,88	1,75	1,37	3,29	1,98	2,29	2,69	3,67	3,52	2,81	4,45	2,22	5,50	1,80	6,65	1,49		
	8	0,57	2,72	1,01	1,53	1,57	2,88	2,26	2,00	3,08	3,21	4,02	2,46	5,09	1,94	6,28	1,58	7,60	1,30		
Number of cooling channels		2,2		2,3		2,4		2,5		2,6		2,7		2,8		2,9		3,0			
		A _{out} [mm ²]	MQL ratio	A _{out} [mm ²]	MQL ratio	A _{out} [mm ²]	MQL ratio	A _{out} [mm ²]	MQL ratio	A _{out} [mm ²]	MQL ratio	A _{out} [mm ²]	MQL ratio	A _{out} [mm ²]	MQL ratio	A _{out} [mm ²]	MQL ratio	A _{out} [mm ²]	MQL ratio		
	1	3,80	2,60	4,15	2,38	4,52	2,19	4,91	2,02	5,31	1,86	5,73	1,73	6,16	1,61	6,61	1,50	7,07	1,40		
	2	7,60	1,30	8,31	1,19	9,05	1,09	9,82	1,01	10,62	0,93	11,45	0,86	12,32		13,21		14,14			
	3	11,40	0,87	12,46		13,57		14,73		15,93		17,18		18,47		19,82		21,21			
	4	15,21		16,62		18,10		19,63		21,24		22,90		24,63		26,42		28,27			
	5	19,01		20,77		22,62		24,54		26,55		28,63		30,79		33,03		35,34			
	6	22,81		24,93		27,14		29,45		31,86		34,35		36,95		39,63		42,41			
7	26,61		29,08		31,67		34,36		37,17		40,08		43,10		46,24		49,48				
8	30,41		33,24		36,19		39,27		42,47		45,80		49,26		52,84		56,55				

too large permissible with limitations

	1,2		1,3		1,4		1,5		1,6		1,7		1,8		1,9		2,0		2,1	
	A _{out} [mm ²]	MQL ratio	A _{out} [mm ²]	MQL ratio	A _{out} [mm ²]	MQL ratio	A _{out} [mm ²]	MQL ratio	A _{out} [mm ²]	MQL ratio	A _{out} [mm ²]	MQL ratio	A _{out} [mm ²]	MQL ratio	A _{out} [mm ²]	MQL ratio	A _{out} [mm ²]	MQL ratio	A _{out} [mm ²]	MQL ratio
	1,13	4,00	1,33	3,41	1,54	2,94	1,77	2,56	2,01	2,25	2,27	1,99	2,54	3,89	2,84	3,49	3,14	3,15	3,46	2,86
	2,26	2,00	2,65	3,73	3,08	3,21	3,53	2,80	4,02	2,46	4,54	2,18	5,09	1,94	5,67	1,75	6,28	1,58	6,93	1,43
	3,39	2,92	3,98	2,49	4,62	2,14	5,30	1,87	6,03	1,64	6,81	1,45	7,63	1,30	8,51	1,16	9,42	1,05	10,39	0,95
	4,52	2,19	5,31	1,86	6,16	1,61	7,07	1,40	8,04	1,23	9,08	1,09	10,18	0,97	11,34	0,87	12,57		13,85	
	5,65	1,75	6,64	1,49	7,70	1,29	8,84	1,12	10,05	0,98	11,35	0,87	12,72		14,18		15,71		17,32	
	6,79	1,46	7,96	1,24	9,24	1,07	10,60	0,93	12,06		13,62		15,27		17,01		18,85		20,78	
	7,92	1,25	9,29	1,07	10,78	0,92	12,37		14,07		15,89		17,81		19,85		21,99		24,25	
	9,05	1,09	10,62	0,93	12,32		14,14		16,08		18,16		20,36		22,68		25,13		27,71	
	3,1		3,2		3,3		3,4		3,5		3,6		3,7		3,8		3,9		4,0	
	A _{out} [mm ²]	MQL ratio	A _{out} [mm ²]	MQL ratio	A _{out} [mm ²]	MQL ratio	A _{out} [mm ²]	MQL ratio	A _{out} [mm ²]	MQL ratio	A _{out} [mm ²]	MQL ratio	A _{out} [mm ²]	MQL ratio	A _{out} [mm ²]	MQL ratio	A _{out} [mm ²]	MQL ratio	A _{out} [mm ²]	MQL ratio
	7,55	1,31	8,04	1,23	8,55	1,16	9,08	1,09	9,62	1,03	10,18		10,75		11,34		11,95		12,57	
	15,10		16,08		17,11		18,16		19,24		20,36		21,50		22,68		23,89		25,13	
	22,64		24,13		25,66		27,24		28,86		30,54		32,26		34,02		35,84		37,70	
	30,19		32,17		34,21		36,32		38,48		40,72		43,01		45,36		47,78		50,27	
	37,74		40,21		42,76		45,40		48,11		50,89		53,76		56,71		59,73		62,83	
	45,29		48,25		51,32		54,48		57,73		61,07		64,51		68,05		71,68		75,40	
	52,83		56,30		59,87		63,55		67,35		71,25		75,26		79,39		83,62		87,96	
	60,38		64,34		68,42		72,63		76,97		81,43		86,02		90,73		95,57		100,53	



Taking into account the MQL ratio to be maintained for the 2-channel system, the tool is not suitable for MQL. It is imperative the tool is changed.

Selection system example for determining the variant

For 2-channel system chucks with diameter 20 - 32 mm

		Mounting diameter																	
		20 - 32																	
		Cooling channel diameter																	
		0,3		0,4		0,5		0,6		0,7		0,8		0,9		1,0		1,1	
		A _{out} [mm ²]	MQL ratio	A _{out} [mm ²]	MQL ratio	A _{out} [mm ²]	MQL ratio	A _{out} [mm ²]	MQL ratio	A _{out} [mm ²]	MQL ratio	A _{out} [mm ²]	MQL ratio	A _{out} [mm ²]	MQL ratio	A _{out} [mm ²]	MQL ratio	A _{out} [mm ²]	MQL ratio
Number of cooling channels	1	0,07		0,13		0,20		0,28		0,38		0,50		0,64	7,11	0,79	5,76	0,95	4,76
	2	0,14		0,25		0,39		0,57	8,00	0,77	5,88	1,01	4,50	1,27	3,56	1,57	2,88	1,90	2,38
	3	0,21		0,38		0,59	7,68	0,85	5,33	1,15	3,92	1,51	3,00	1,91	2,37	2,36	1,92	2,85	3,47
	4	0,28		0,50		0,79	5,76	1,13	4,00	1,54	2,94	2,01	2,25	2,54	3,89	3,14	3,15	3,80	2,60
	5	0,35		0,63	7,20	0,98	4,61	1,41	3,20	1,92	2,35	2,51	3,94	3,18	3,11	3,93	2,52	4,75	3,65
	6	0,42		0,75	6,00	1,18	3,84	1,70	2,67	2,31	1,96	3,02	3,28	3,82	2,59	4,71	3,68	5,70	3,04
	7	0,49		0,88	5,14	1,37	3,29	1,98	2,29	2,69	3,67	3,52	2,81	4,45	3,90	5,50	3,16	6,65	2,61
	8	0,57	8,00	1,01	4,50	1,57	2,88	2,26	2,00	3,08	3,21	4,02	2,46	5,09	3,41	6,28	2,76	7,60	2,28
		2,2		2,3		2,4		2,5		2,6		2,7		2,8		2,9		3,0	
		A _{out} [mm ²]	MQL ratio	A _{out} [mm ²]	MQL ratio	A _{out} [mm ²]	MQL ratio	A _{out} [mm ²]	MQL ratio	A _{out} [mm ²]	MQL ratio	A _{out} [mm ²]	MQL ratio	A _{out} [mm ²]	MQL ratio	A _{out} [mm ²]	MQL ratio	A _{out} [mm ²]	MQL ratio
Number of cooling channels	1	3,80	2,60	4,15	2,38	4,52	3,84	4,91	3,53	5,31	3,27	5,73	3,03	6,16	2,82	6,61	2,63	7,07	2,45
	2	7,60	2,28	8,31	2,09	9,05	1,92	9,82	1,77	10,62	1,63	11,45	1,52	12,32	1,41	13,21	1,31	14,14	1,23
	3	11,40	1,52	12,46	1,39	13,57	1,28	14,73	1,18	15,93	1,09	17,18	1,01	18,47	0,94	19,82	0,88	21,21	
	4	15,21	1,14	16,62	1,04	18,10	0,96	19,63	0,88	21,24		22,90		24,63		26,42		28,27	
	5	19,01	0,91	20,77		22,62		24,54		26,55		28,63		30,79		33,03		35,34	
	6	22,81		24,93		27,14		29,45		31,86		34,35		36,95		39,63		42,41	
	7	26,61		29,08		31,67		34,36		37,17		40,08		43,10		46,24		49,48	
	8	30,41		33,24		36,19		39,27		42,47		45,80		49,26		52,84		56,55	

too large permissible with limitations

	1,2		1,3		1,4		1,5		1,6		1,7		1,8		1,9		2,0		2,1	
	A _{out} [mm ²]	MQL ratio	A _{out} [mm ²]	MQL ratio	A _{out} [mm ²]	MQL ratio	A _{out} [mm ²]	MQL ratio	A _{out} [mm ²]	MQL ratio	A _{out} [mm ²]	MQL ratio	A _{out} [mm ²]	MQL ratio	A _{out} [mm ²]	MQL ratio	A _{out} [mm ²]	MQL ratio	A _{out} [mm ²]	MQL ratio
	1,13	4,00	1,33	3,41	1,54	2,94	1,77	2,56	2,01	2,25	2,27	1,99	2,54	3,89	2,84	3,49	3,14	3,15	3,46	2,86
	2,26	2,00	2,65	3,73	3,08	3,21	3,53	2,80	4,02	2,46	4,54	3,82	5,09	3,41	5,67	3,06	6,28	2,76	6,93	2,50
	3,39	2,92	3,98	2,49	4,62	3,76	5,30	3,27	6,03	2,88	6,81	2,55	7,63	2,27	8,51	2,04	9,42	1,84	10,39	1,67
	4,52	3,84	5,31	3,27	6,16	2,82	7,07	2,45	8,04	2,16	9,08	1,91	10,18	1,70	11,34	1,53	12,57	1,38	13,85	1,25
	5,65	3,07	6,64	2,61	7,70	2,25	8,84	1,96	10,05	1,73	11,35	1,53	12,72	1,36	14,18	1,22	15,71	1,10	17,32	1,00
	6,79	2,56	7,96	2,18	9,24	1,88	10,60	1,64	12,06	1,44	13,62	1,27	15,27	1,14	17,01	1,02	18,85		20,78	
	7,92	2,19	9,29	1,87	10,78	1,61	12,37	1,40	14,07	1,23	15,89	1,09	17,81		19,85		21,99		24,25	
	9,05	1,92	10,62	1,63	12,32	1,41	14,14	1,23	16,08	1,08	18,16		20,36		22,68		25,13		27,71	
	3,1		3,2		3,3		3,4		3,5		3,6		3,7		3,8		3,9		4,0	
	A _{out} [mm ²]	MQL ratio	A _{out} [mm ²]	MQL ratio	A _{out} [mm ²]	MQL ratio	A _{out} [mm ²]	MQL ratio	A _{out} [mm ²]	MQL ratio	A _{out} [mm ²]	MQL ratio	A _{out} [mm ²]	MQL ratio	A _{out} [mm ²]	MQL ratio	A _{out} [mm ²]	MQL ratio	A _{out} [mm ²]	MQL ratio
	7,55	2,30	8,04	2,16	8,55	2,03	9,08	1,91	9,62	1,80	10,18	1,70	10,75	1,61	11,34	1,53	11,95	1,45	12,57	1,38
	15,10	1,15	16,08	1,08	17,11	1,01	18,16	0,96	19,24	0,90	20,36	0,85	21,50		22,68		23,89		25,13	
	22,64		24,13		25,66		27,24		28,86		30,54		32,26		34,02		35,84		37,70	
	30,19		32,17		34,21		36,32		38,48		40,72		43,01		45,36		47,78		50,27	
	37,74		40,21		42,76		45,40		48,11		50,89		53,76		56,71		59,73		62,83	
	45,29		48,25		51,32		54,48		57,73		61,07		64,51		68,05		71,68		75,40	
	52,83		56,30		59,87		63,55		67,35		71,25		75,26		79,39		83,62		87,96	
	60,38		64,34		68,42		72,63		76,97		81,43		86,02		90,73		95,57		100,53	



Taking into account the MQL ratio to be maintained for the 2-channel system, the tool is not suitable for MQL. It is imperative the tool is changed.

2-channel system MQL hydraulic chucks HydroChuck

For automatic tool change, with axial tool length adjustment
Shank HSK-A in accordance with DIN 69893-1

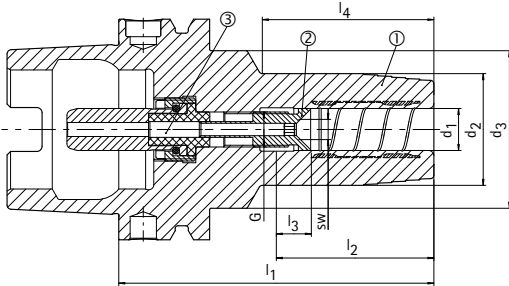

- ① Hydraulic chucks, HSK, MQL, body material | BDY
- ② Length adjustment screw, MQL | LS
- ③ Coolant supply unit, MQL, automatic | CU



Preferred series in stock

Variant*	HSK-A	Dimensions							G	A _{IN} mm ²	sw	Components			Specification	Order No.
		d ₁	d ₂	d ₃	l ₁	l ₂	l ₃	l ₄				BDY	LS	CU		
	63	6	26	45	80	36	10	37	M10x1	1,54	1,5	30386549	30512784	30512203	MHC-HSK-A063-06-080-C-0-A-AAA1	30522882
	63	6	26	45	80	36	10	37	M10x1	4,52	2	30386549	30384039	30384304	MHC-HSK-A063-06-080-C-0-A-AAA2	30386278
	63	6	26	38	120	36	10	78	M5	1,54	1,5	30464609	30512804	30512203	MHC-HSK-A063-06-120-C-0-A-AAA1	30522916
	63	6	26	38	120	36	10	78	M5	4,52	2	30464609	30384040	30384304	MHC-HSK-A063-06-120-C-0-A-AAA2	30485332
	63	8	28	45	80	36	10	37,5	M10x1	1,54	1,5	30386550	30512785	30512203	MHC-HSK-A063-08-080-C-0-A-AAA1	30522883
	63	8	28	45	80	36	10	37,5	M10x1	4,52	2	30386550	30384043	30384304	MHC-HSK-A063-08-080-C-0-A-AAA2	30386279
	63	8	28	38	120	36	10	78,5	M7	1,54	1,5	30464610	30512805	30512203	MHC-HSK-A063-08-120-C-0-A-AAA1	30522917
	63	8	28	38	120	36	10	78,5	M7	4,52	2	30464610	30384044	30384304	MHC-HSK-A063-08-120-C-0-A-AAA2	30485333
	63	10	30	45	85	40	10	43,5	M10x1	1,54	1,5	30386551	30512786	30512203	MHC-HSK-A063-10-085-C-0-A-AAA1	30522884
	63	10	30	45	85	40	10	43,5	M10x1	4,52	2	30386551	30384011	30384304	MHC-HSK-A063-10-085-C-0-A-AAA2	30386280
	63	10	30	40	120	40	10	79	M8x1	1,54	1,5	30464611	30512806	30512203	MHC-HSK-A063-10-120-C-0-A-AAA1	30522918
	63	10	30	40	120	40	10	79	M8x1	4,52	2	30464611	30384012	30384304	MHC-HSK-A063-10-120-C-0-A-AAA2	30485334
	63	12	32	45	90	45	10	49	M10x1	1,54	1,5	30386552	30512791	30512203	MHC-HSK-A063-12-090-C-0-A-AAA1	30522885
	63	12	32	45	90	45	10	49	M10x1	4,52	2	30386552	30512787	30384304	MHC-HSK-A063-12-090-C-0-A-AAA2	30522886
	63	12	32	45	90	45	10	49	M10x1	9,9	3	30386552	30279400	30284772	MHC-HSK-A063-12-090-C-0-A-AAA3	30386281
	63	12	32	40	120	45	10	80,5	M10x1	1,54	1,5	30464612	30512811	30512203	MHC-HSK-A063-12-120-C-0-A-AAA1	30522919
	63	12	32	40	120	45	10	80,5	M10x1	4,52	2	30464612	30512807	30384304	MHC-HSK-A063-12-120-C-0-A-AAA2	30522920
	63	12	32	40	120	45	10	80,5	M10x1	9,9	3	30464612	30279402	30284772	MHC-HSK-A063-12-120-C-0-A-AAA3	30485335
	63	14	34	45	90	45	10	49,5	M10x1	1,54	1,5	30386553	30512792	30512203	MHC-HSK-A063-14-090-C-0-A-AAA1	30522887
	63	14	34	45	90	45	10	49,5	M10x1	4,52	2	30386553	30512788	30384304	MHC-HSK-A063-14-090-C-0-A-AAA2	30522888
	63	14	34	45	90	45	10	49,5	M10x1	9,9	3	30386553	30279407	30284772	MHC-HSK-A063-14-090-C-0-A-AAA3	30386282
	63	14	34	40	120	45	10	81	M10x1	1,54	1,5	30464613	30512813	30512203	MHC-HSK-A063-14-120-C-0-A-AAA1	30522921
	63	14	34	40	120	45	10	81	M10x1	4,52	2	30464613	30512808	30384304	MHC-HSK-A063-14-120-C-0-A-AAA2	30522922
	63	14	34	40	120	45	10	81	M10x1	9,9	3	30464613	30279408	30284772	MHC-HSK-A063-14-120-C-0-A-AAA3	30485336
	63	16	38	45	95	48	10	55,5	M12x1	1,54	1,5	30386554	30512793	30512203	MHC-HSK-A063-16-095-C-0-A-AAA1	30522889
	63	16	38	45	95	48	10	55,5	M12x1	4,52	2	30386554	30512789	30384304	MHC-HSK-A063-16-095-C-0-A-AAA2	30522890
	63	16	38	45	95	48	10	55,5	M12x1	9,9	3	30386554	30279413	30284772	MHC-HSK-A063-16-095-C-0-A-AAA3	30386283
	63	16	38	-	120	48	10	91,1	M12x1	1,54	1,5	30464614	30512814	30512203	MHC-HSK-A063-16-120-C-0-A-AAA1	30522923
	63	16	38	-	120	48	10	91,1	M12x1	4,52	2	30464614	30512809	30384304	MHC-HSK-A063-16-120-C-0-A-AAA2	30522924
	63	16	38	-	120	48	10	91,1	M12x1	9,9	3	30464614	30279414	30284772	MHC-HSK-A063-16-120-C-0-A-AAA3	30485337
	63	18	40	45	95	48	10	56	M12x1	1,54	1,5	30386555	30512794	30512203	MHC-HSK-A063-18-095-C-0-A-AAA1	30522891
	63	18	40	45	95	48	10	56	M12x1	4,52	2	30386555	30512790	30384304	MHC-HSK-A063-18-095-C-0-A-AAA2	30522892
	63	18	40	45	95	48	10	56	M12x1	9,9	3	30386555	30279420	30284772	MHC-HSK-A063-18-095-C-0-A-AAA3	30386284
	63	18	40	-	120	48	10	89,1	M12x1	1,54	1,5	30464615	30512815	30512203	MHC-HSK-A063-18-120-C-0-A-AAA1	30522925
	63	18	40	-	120	48	10	89,1	M12x1	4,52	2	30464615	30512810	30384304	MHC-HSK-A063-18-120-C-0-A-AAA2	30522926
	63	18	40	-	120	48	10	89,1	M12x1	9,9	3	30464615	30279422	30284772	MHC-HSK-A063-18-120-C-0-A-AAA3	30485338
	63	20	42	50	100	50	10	60,5	M16x1	4,52	2	30386556	30512798	30384304	MHC-HSK-A063-20-100-C-0-A-AAA1	30522893
	63	20	42	50	100	50	10	60,5	M16x1	9,9	3	30386556	30512795	30284772	MHC-HSK-A063-20-100-C-0-A-AAA2	30522894
	63	20	42	50	100	50	10	60,5	M16x1	17,35	4	30386556	30279429	30279444	MHC-HSK-A063-20-100-C-0-A-AAA3	30386285

2-channel system MQL hydraulic chucks HydroChuck | For automatic tool change, with axial tool length adjustment
Shank HSK-A in accordance with DIN 69893-1 | Preferred series in stock

Variant*	HSK-A	Dimensions							G	A _{IN}	sw	Components			Specification	Order No.
		d ₁	d ₂	d ₃	l ₁	l ₂	l ₃	l ₄				BDY	LS	CU		
	63	20	42	-	120	50	10	89,1	M16x1	4,52	2	30464616	30512817	30384304	MHC-HSK-A063-20-120-C-0-A-AAA1	30522927
	63	20	42	-	120	50	10	89,1	M16x1	9,9	3	30464616	30512816	30284772	MHC-HSK-A063-20-120-C-0-A-AAA2	30522928
	63	20	42	-	120	50	10	89,1	M16x1	17,35	4	30464616	30279422	30279444	MHC-HSK-A063-20-120-C-0-A-AAA3	30485339
	63	25	57	-	115	56	10	89	M16x1	4,52	2	30386557	30512799	30384304	MHC-HSK-A063-25-115-C-0-A-AAA1	30522895
	63	25	57	-	115	56	10	89	M16x1	9,9	3	30386557	30512796	30284772	MHC-HSK-A063-25-115-C-0-A-AAA2	30522896
	63	25	57	-	115	56	10	89	M16x1	17,35	4	30386557	30279434	30279444	MHC-HSK-A063-25-115-C-0-A-AAA3	30386286
	63	32	63	-	120	60	10	94	M16x1	4,52	2	30386558	30512800	30384304	MHC-HSK-A063-32-120-C-0-A-AAA1	30522897
	63	32	63	-	120	60	10	94	M16x1	9,9	3	30386558	30512797	30284772	MHC-HSK-A063-32-120-C-0-A-AAA2	30522898
	63	32	63	-	120	60	10	94	M16x1	17,35	4	30386558	30279441	30279444	MHC-HSK-A063-32-120-C-0-A-AAA3	30386287
	100	6	26	45	85	36	10	36,5	M10x1	1,54	1,5	30386569	30512784	30521106	MHC-HSK-A100-06-085-C-0-A-AAA1	30523138
	100	6	26	45	85	36	10	36,5	M10x1	4,52	2	30386569	30384039	30384306	MHC-HSK-A100-06-085-C-0-A-AAA2	30386319
	100	8	28	45	85	36	10	37	M10x1	1,54	1,5	30386570	30512785	30521106	MHC-HSK-A100-08-085-C-0-A-AAA1	30523139
	100	8	28	45	85	36	10	37	M10x1	4,52	2	30386570	30384043	30384306	MHC-HSK-A100-08-085-C-0-A-AAA2	30386320
	100	10	30	45	90	40	10	43	M10x1	1,54	1,5	30386571	30512786	30521106	MHC-HSK-A100-10-090-C-0-A-AAA1	30523140
	100	10	30	45	90	40	10	43	M10x1	4,52	2	30386571	30384011	30384306	MHC-HSK-A100-10-090-C-0-A-AAA2	30386321
	100	12	32	45	95	45	10	48,5	M10x1	1,54	1,5	30386572	30512791	30521106	MHC-HSK-A100-12-095-C-0-A-AAA1	30523141
	100	12	32	45	95	45	10	48,5	M10x1	4,52	2	30386572	30512787	30384306	MHC-HSK-A100-12-095-C-0-A-AAA2	30523142
	100	12	32	45	95	45	10	48,5	M10x1	9,9	3	30386572	30279400	30297309	MHC-HSK-A100-12-095-C-0-A-AAA3	30386322
	100	14	34	45	95	45	10	49	M10x1	1,54	1,5	30386573	30512792	30521106	MHC-HSK-A100-14-095-C-0-A-AAA1	30523143
	100	14	34	45	95	45	10	49	M10x1	4,52	2	30386573	30512788	30384306	MHC-HSK-A100-14-095-C-0-A-AAA2	30523144
	100	14	34	45	95	45	10	49	M10x1	9,9	3	30386573	30279407	30297309	MHC-HSK-A100-14-095-C-0-A-AAA3	30386323
	100	16	38	45	100	48	10	55	M12x1	1,54	1,5	30386574	30512793	30521106	MHC-HSK-A100-16-100-C-0-A-AAA1	30523145
	100	16	38	45	100	48	10	55	M12x1	4,52	2	30386574	30512789	30384306	MHC-HSK-A100-16-100-C-0-A-AAA2	30523146
	100	16	38	45	100	48	10	55	M12x1	9,9	3	30386574	30279413	30297309	MHC-HSK-A100-16-100-C-0-A-AAA3	30386324
	100	18	40	45	100	48	10	55,5	M12x1	1,54	1,5	30386575	30512794	30521106	MHC-HSK-A100-18-100-C-0-A-AAA1	30523147
	100	18	40	45	100	48	10	55,5	M12x1	4,52	2	30386575	30512790	30384306	MHC-HSK-A100-18-100-C-0-A-AAA2	30523148
	100	18	40	45	100	48	10	55,5	M12x1	9,9	3	30386575	30279420	30297309	MHC-HSK-A100-18-100-C-0-A-AAA3	30386325
	100	20	42	50	105	50	10	60	M16x1	4,52	2	30386576	30512798	30384306	MHC-HSK-A100-20-105-C-0-A-AAA1	30523149
	100	20	42	50	105	50	10	60	M16x1	9,9	3	30386576	30512795	30297309	MHC-HSK-A100-20-105-C-0-A-AAA2	30523150
	100	20	42	50	105	50	10	60	M16x1	17,35	4	30386576	30279429	30297310	MHC-HSK-A100-20-105-C-0-A-AAA3	30386326
	100	25	57	-	115	56	10	86	M16x1	4,52	2	30386577	30512799	30384306	MHC-HSK-A100-25-115-C-0-A-AAA1	30523151
	100	25	57	-	115	56	10	86	M16x1	9,9	3	30386577	30512796	30297309	MHC-HSK-A100-25-115-C-0-A-AAA2	30523152
	100	25	57	-	115	56	10	86	M16x1	17,35	4	30386577	30279434	30297310	MHC-HSK-A100-25-115-C-0-A-AAA3	30386327
	100	32	63	-	120	60	10	91	M16x1	4,52	2	30386578	30512800	30384306	MHC-HSK-A100-32-120-C-0-A-AAA1	30523153
	100	32	63	-	120	60	10	91	M16x1	9,9	3	30386578	30512797	30297309	MHC-HSK-A100-32-120-C-0-A-AAA2	30523154
	100	32	63	-	120	60	10	91	M16x1	17,35	4	30386578	30279441	30297310	MHC-HSK-A100-32-120-C-0-A-AAA3	30386328

* The exact determination of the variant can be found in the selection system 2-channel system chucks.
The preferred series is marked with a green .

Dimensions in mm.

Use: For clamping tools with smooth cylindrical shanks according to DIN 1835 Form A, DIN 6535 Form HA as well as with recesses according to DIN 1835 Form B, E and DIN 6535 Form HB, HE directly and without reducing sleeve in the clamping diameter. The clamping diameter is designed for a shank tolerance h6.

Items included: Tool body, length adjustment screw and coolant unit as assembly. These components can also be ordered separately. (see table)

Design: Longest tool lives and highest manufacturing quality on usage of smooth cylindrical shanks in accordance with DIN 1835 Form A and DIN 6535 Form HA. With a projection length of 2.5 x D (max. 50 mm) radial run-out accuracy 3 µm. On usage of cylindrical shanks with angled clamping surface (Form E and Form HE) the accuracy may be affected. Different versions with chip available on request. Balancing value: G 2.5 at 25,000 min⁻¹ as delivered.

2-channel system MQL hydraulic chucks HydroChuck

For automatic tool change, with axial tool length adjustment
Shank HSK-A in accordance with DIN 69893-1

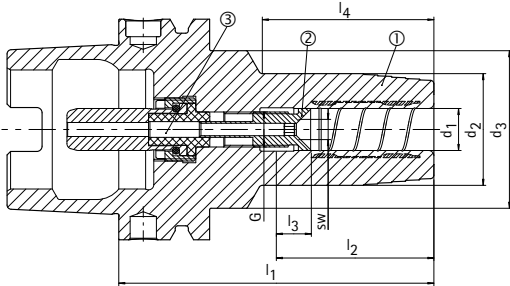

- ① Hydraulic chucks, HSK, MQL, body material | BDY
- ② Length adjustment screw, MQL | LS
- ③ Coolant supply unit, MQL, automatic | CU



Available on request

Variant*	HSK-A	Dimensions							G	A _{IN} mm ²	sw	Components			Specification	Order No.
		d ₁	d ₂	d ₃	l ₁	l ₂	l ₃	l ₄				BDY	LS	CU		
	40	6	26	33,5	80	36	10	49	M7	1,54	1,5	30386529	30512726	30521102	MHC-HSK-A040-06-080-C-0-A-AAA1	30522750
	40	6	26	33,5	80	36	10	49	M7	4,52	2	30386529	30383971	30384302	MHC-HSK-A040-06-080-C-0-A-AAA2	30386249
	40	6	26	33,5	120	36	10	86	M5	1,54	1,5	30464569	30512735	30521102	MHC-HSK-A040-06-120-C-0-A-AAA1	30522768
	40	6	26	33,5	120	36	10	86	M5	4,52	2	30464569	30383972	30384302	MHC-HSK-A040-06-120-C-0-A-AAA2	30485276
	40	6	26	33,5	160	36	10	118	M5	1,54	1,5	30464575	30512744	30521102	MHC-HSK-A040-06-160-C-0-A-AAA1	30522786
	40	6	26	33,5	160	36	10	118	M5	4,52	2	30464575	30383973	30384302	MHC-HSK-A040-06-160-C-0-A-AAA2	30485288
	40	8	28	33,5	80	36	10	50,5	M7	1,54	1,5	30386530	30512727	30521102	MHC-HSK-A040-08-080-C-0-A-AAA1	30522751
	40	8	28	33,5	80	36	10	50,5	M7	4,52	2	30386530	30383974	30384302	MHC-HSK-A040-08-080-C-0-A-AAA2	30386250
	40	8	28	33,5	120	36	10	86,5	M7	1,54	1,5	30464570	30512736	30521102	MHC-HSK-A040-08-120-C-0-A-AAA1	30522769
	40	8	28	33,5	120	36	10	86,5	M7	4,52	2	30464570	30383975	30384302	MHC-HSK-A040-08-120-C-0-A-AAA2	30485277
	40	8	28	33,5	160	36	10	118	M7	1,54	1,5	30464576	30512745	30521102	MHC-HSK-A040-08-160-C-0-A-AAA1	30522787
	40	8	28	33,5	160	36	10	118	M7	4,52	2	30464576	30383976	30384302	MHC-HSK-A040-08-160-C-0-A-AAA2	30485289
	40	10	30	33,5	80	40	10	52	M8x1	1,54	1,5	30386531	30512728	30521102	MHC-HSK-A040-10-080-C-0-A-AAA1	30522752
	40	10	30	33,5	80	40	10	52	M8x1	4,52	2	30386531	30383959	30384302	MHC-HSK-A040-10-080-C-0-A-AAA2	30386251
	40	10	30	33,5	120	40	10	87	M8x1	1,54	1,5	30464571	30512737	30521102	MHC-HSK-A040-10-120-C-0-A-AAA1	30522770
	40	10	30	33,5	120	40	10	87	M8x1	4,52	2	30464571	30383960	30384302	MHC-HSK-A040-10-120-C-0-A-AAA2	30485278
	40	10	30	33,5	160	40	10	127	M8x1	1,54	1,5	30464577	30512746	30521102	MHC-HSK-A040-10-160-C-0-A-AAA1	30522788
	40	10	30	33,5	160	40	10	127	M8x1	4,52	2	30464577	30383961	30384302	MHC-HSK-A040-10-160-C-0-A-AAA2	30485290
	40	12	32	33,5	90	45	10	62	M10x1	1,54	1,5	30386532	30512732	30521102	MHC-HSK-A040-12-090-C-0-A-AAA1	30522753
	40	12	32	33,5	90	45	10	62	M10x1	4,52	2	30386532	30512729	30384302	MHC-HSK-A040-12-090-C-0-A-AAA2	30522754
	40	12	32	33,5	90	45	10	62	M10x1	9,9	3	30386532	30280050	30297304	MHC-HSK-A040-12-090-C-0-A-AAA3	30386252
	40	12	32	33,5	120	45	10	91,5	M10x1	1,54	1,5	30464572	30512741	30521102	MHC-HSK-A040-12-120-C-0-A-AAA1	30522771
	40	12	32	33,5	120	45	10	91,5	M10x1	4,52	2	30464572	30512738	30384302	MHC-HSK-A040-12-120-C-0-A-AAA2	30522772
	40	12	32	33,5	120	45	10	91,5	M10x1	9,9	3	30464572	30302842	30297304	MHC-HSK-A040-12-120-C-0-A-AAA3	30485279
	40	12	32	33,5	160	45	10	126	M10x1	1,54	1,5	30464578	30512750	30521102	MHC-HSK-A040-12-160-C-0-A-AAA1	30522789
	40	12	32	33,5	160	45	10	126	M10x1	4,52	2	30464578	30512747	30384302	MHC-HSK-A040-12-160-C-0-A-AAA2	30522790
	40	12	32	33,5	160	45	10	126	M10x1	9,9	3	30464578	30302848	30297304	MHC-HSK-A040-12-160-C-0-A-AAA3	30485291
	40	14	34	45	90	45	10	39,5	M10x1	1,54	1,5	30386533	30512733	30521102	MHC-HSK-A040-14-090-C-0-A-AAA1	30522755
	40	14	34	45	90	45	10	39,5	M10x1	4,52	2	30386533	30512730	30384302	MHC-HSK-A040-14-090-C-0-A-AAA2	30522756
	40	14	34	45	90	45	10	39,5	M10x1	9,9	3	30386533	30280051	30297304	MHC-HSK-A040-14-090-C-0-A-AAA3	30386253
	40	14	34	-	120	45	10	100	M10x1	1,54	1,5	30464573	30512742	30521102	MHC-HSK-A040-14-120-C-0-A-AAA1	30522773
	40	14	34	-	120	45	10	100	M10x1	4,52	2	30464573	30512739	30384302	MHC-HSK-A040-14-120-C-0-A-AAA2	30522774
	40	14	34	-	120	45	10	100	M10x1	9,9	3	30464573	30302843	30297304	MHC-HSK-A040-14-120-C-0-A-AAA3	30485280
	40	14	34	-	160	45	10	140	M10x1	1,54	1,5	30464579	30512751	30521102	MHC-HSK-A040-14-160-C-0-A-AAA1	30522791
	40	14	34	-	160	45	10	140	M10x1	4,52	2	30464579	30512748	30384302	MHC-HSK-A040-14-160-C-0-A-AAA2	30522792
	40	14	34	-	160	45	10	140	M10x1	9,9	3	30464579	30302849	30297304	MHC-HSK-A040-14-160-C-0-A-AAA3	30485292
	40	16	38	50	90	48	10	39	M12x1	1,54	1,5	30386534	30512734	30521102	MHC-HSK-A040-16-090-C-0-A-AAA1	30522757
	40	16	38	50	90	48	10	39	M12x1	4,52	2	30386534	30512731	30384302	MHC-HSK-A040-16-090-C-0-A-AAA2	30522758
	40	16	38	50	90	48	10	39	M12x1	9,9	3	30386534	30280052	30297304	MHC-HSK-A040-16-090-C-0-A-AAA3	30386254

2-channel system MQL hydraulic chucks HydroChuck | For automatic tool change, with axial tool length adjustment
Shank HSK-A in accordance with DIN 69893-1 | Available on request

Variant*	HSK-A	Dimensions							G	A _{IN}	sw	Components			Specification	Order No.
		d ₁	d ₂	d ₃	l ₁	l ₂	l ₃	l ₄				BDY	LS	CU		
	40	16	38	-	120	48	10	100	M12x1	1,54	1,5	30464574	30512743	30521102	MHC-HSK-A040-16-120-C-0-A-AAA1	30522775
	40	16	38	-	120	48	10	100	M12x1	4,52	2	30464574	30512740	30384302	MHC-HSK-A040-16-120-C-0-A-AAA2	30522776
	40	16	38	-	120	48	10	100	M12x1	9,9	3	30464574	30302844	30297304	MHC-HSK-A040-16-120-C-0-A-AAA3	30485281
	40	16	38	-	160	48	10	140	M12x1	1,54	1,5	30464580	30512752	30521102	MHC-HSK-A040-16-160-C-0-A-AAA1	30522793
	40	16	38	-	160	48	10	140	M12x1	4,52	2	30464580	30512749	30384302	MHC-HSK-A040-16-160-C-0-A-AAA2	30522794
	40	16	38	-	160	48	10	140	M12x1	9,9	3	30464580	30302850	30297304	MHC-HSK-A040-16-160-C-0-A-AAA3	30485293
	50	6	26	40	80	36	10	38,5	M8x1	1,54	1,5	30386541	30512753	30521103	MHC-HSK-A050-06-080-C-0-A-AAA1	30522804
	50	6	26	40	80	36	10	38,5	M8x1	4,52	2	30386541	30384009	30384303	MHC-HSK-A050-06-080-C-0-A-AAA2	30386261
	50	6	26	35	120	36	10	80	M5	1,54	1,5	30464593	30512756	30521103	MHC-HSK-A050-06-120-C-0-A-AAA1	30522830
	50	6	26	35	120	36	10	80	M5	4,52	2	30464593	30383998	30384303	MHC-HSK-A050-06-120-C-0-A-AAA2	30485300
	50	6	26	35	160	36	10	118	M5	1,54	1,5	30464601	30512770	30521103	MHC-HSK-A050-06-160-C-0-A-AAA1	30522856
	50	6	26	35	160	36	10	118	M5	4,52	2	30464601	30383999	30384303	MHC-HSK-A050-06-160-C-0-A-AAA2	30485316
	50	8	28	40	80	36	10	39	M8x1	1,54	1,5	30386542	30512754	30521103	MHC-HSK-A050-08-080-C-0-A-AAA1	30522805
	50	8	28	40	80	36	10	39	M8x1	4,52	2	30386542	30384010	30384303	MHC-HSK-A050-08-080-C-0-A-AAA2	30386262
	50	8	28	35	120	36	10	80	M7	1,54	1,5	30464594	30512757	30521103	MHC-HSK-A050-08-120-C-0-A-AAA1	30522831
	50	8	28	35	120	36	10	80	M7	4,52	2	30464594	30384001	30384303	MHC-HSK-A050-08-120-C-0-A-AAA2	30485301
	50	8	28	35	160	36	10	118	M7	1,54	1,5	30464602	30512771	30521103	MHC-HSK-A050-08-160-C-0-A-AAA1	30522857
	50	8	28	35	160	36	10	118	M7	4,52	2	30464602	30384002	30384303	MHC-HSK-A050-08-160-C-0-A-AAA2	30485317
	50	10	30	40	85	40	10	44,5	M8x1	1,54	1,5	30386543	30512755	30521103	MHC-HSK-A050-10-085-C-0-A-AAA1	30522806
	50	10	30	40	85	40	10	44,5	M8x1	4,52	2	30386543	30384004	30384303	MHC-HSK-A050-10-085-C-0-A-AAA2	30386263
	50	10	30	38	120	40	10	80	M8x1	1,54	1,5	30464595	30512758	30521103	MHC-HSK-A050-10-120-C-0-A-AAA1	30522832
	50	10	30	38	120	40	10	80	M8x1	4,52	2	30464595	30383977	30384303	MHC-HSK-A050-10-120-C-0-A-AAA2	30485302
	50	10	30	38	160	40	10	120	M8x1	1,54	1,5	30464603	30512772	30521103	MHC-HSK-A050-10-160-C-0-A-AAA1	30522858
	50	10	30	38	160	40	10	120	M8x1	4,52	2	30464603	30383978	30384303	MHC-HSK-A050-10-160-C-0-A-AAA2	30485318
	50	12	32	40	90	45	10	53	M10x1	1,54	1,5	30386544	30512791	30521103	MHC-HSK-A050-12-090-C-0-A-AAA1	30522807
	50	12	32	40	90	45	10	53	M10x1	4,52	2	30386544	30512787	30384303	MHC-HSK-A050-12-090-C-0-A-AAA2	30522808
	50	12	32	40	90	45	10	53	M10x1	9,9	3	30386544	30279400	30297305	MHC-HSK-A050-12-090-C-0-A-AAA3	30386264
	50	12	32	38	120	45	10	81	M10x1	1,54	1,5	30464596	30512763	30521103	MHC-HSK-A050-12-120-C-0-A-AAA1	30522833
	50	12	32	38	120	45	10	81	M10x1	4,52	2	30464596	30512759	30384303	MHC-HSK-A050-12-120-C-0-A-AAA2	30522834
	50	12	32	38	120	45	10	81	M10x1	9,9	3	30464596	30302854	30297305	MHC-HSK-A050-12-120-C-0-A-AAA3	30485303
	50	12	32	38	160	45	10	121	M10x1	1,54	1,5	30464604	30512777	30521103	MHC-HSK-A050-12-160-C-0-A-AAA1	30522859
	50	12	32	38	160	45	10	121	M10x1	4,52	2	30464604	30512773	30384303	MHC-HSK-A050-12-160-C-0-A-AAA2	30522860
	50	12	32	38	160	45	10	121	M10x1	9,9	3	30464604	30302862	30297305	MHC-HSK-A050-12-160-C-0-A-AAA3	30485319
	50	14	34	40	90	45	10	54,5	M10x1	1,54	1,5	30386545	30512792	30521103	MHC-HSK-A050-14-090-C-0-A-AAA1	30522809
	50	14	34	40	90	45	10	54,5	M10x1	4,52	2	30386545	30512788	30384303	MHC-HSK-A050-14-090-C-0-A-AAA2	30522810
	50	14	34	40	90	45	10	54,5	M10x1	9,9	3	30386545	30279407	30297305	MHC-HSK-A050-14-090-C-0-A-AAA3	30386265
	50	14	34	38	120	45	10	81,5	M10x1	1,54	1,5	30464597	30512764	30521103	MHC-HSK-A050-14-120-C-0-A-AAA1	30522835
	50	14	34	38	120	45	10	81,5	M10x1	4,52	2	30464597	30512760	30384303	MHC-HSK-A050-14-120-C-0-A-AAA2	30522836
	50	14	34	38	120	45	10	81,5	M10x1	9,9	3	30464597	30302855	30297305	MHC-HSK-A050-14-120-C-0-A-AAA3	30485304
	50	14	34	38	160	45	10	121,5	M10x1	1,54	1,5	30464605	30512778	30521103	MHC-HSK-A050-14-160-C-0-A-AAA1	30522861
	50	14	34	38	160	45	10	121,5	M10x1	4,52	2	30464605	30512774	30384303	MHC-HSK-A050-14-160-C-0-A-AAA2	30522862
	50	14	34	38	160	45	10	121,5	M10x1	9,9	3	30464605	30302863	30297305	MHC-HSK-A050-14-160-C-0-A-AAA3	30485320
	50	16	38	41,5	95	48	10	61	M12x1	1,54	1,5	30386546	30512793	30521103	MHC-HSK-A050-16-095-C-0-A-AAA1	30522811
	50	16	38	41,5	95	48	10	61	M12x1	4,52	2	30386546	30512789	30384303	MHC-HSK-A050-16-095-C-0-A-AAA2	30522812
	50	16	38	41,5	95	48	10	61	M12x1	9,9	3	30386546	30279413	30297305	MHC-HSK-A050-16-095-C-0-A-AAA3	30386266
	50	16	38	-	120	48	10	94	M12x1	1,54	1,5	30464598	30512765	30521103	MHC-HSK-A050-16-120-C-0-A-AAA1	30522837
	50	16	38	-	120	48	10	94	M12x1	4,52	2	30464598	30512761	30384303	MHC-HSK-A050-16-120-C-0-A-AAA2	30522838
	50	16	38	-	120	48	10	94	M12x1	9,9	3	30464598	30302856	30297305	MHC-HSK-A050-16-120-C-0-A-AAA3	30485305
	50	16	38	-	160	48	10	134	M12x1	1,54	1,5	30464606	30512779	30521103	MHC-HSK-A050-16-160-C-0-A-AAA1	30522863
	50	16	38	-	160	48	10	134	M12x1	4,52	2	30464606	30512775	30384303	MHC-HSK-A050-16-160-C-0-A-AAA2	30522864
	50	16	38	-	160	48	10	134	M12x1	9,9	3	30464606	30302864	30297305	MHC-HSK-A050-16-160-C-0-A-AAA3	30485321
	50	18	40	41,5	95	48	10	62,5	M12x1	1,54	1,5	30386547	30512794	30521103	MHC-HSK-A050-18-095-C-0-A-AAA1	30522813
	50	18	40	41,5	95	48	10	62,5	M12x1	4,52	2	30386547	30512790	30384303	MHC-HSK-A050-18-095-C-0-A-AAA2	30522814
	50	18	40	41,5	95	48	10	62,5	M12x1	9,9	3	30386547	30279420	30297305	MHC-HSK-A050-18-095-C-0-A-AAA3	30386267
	50	18	40	-	120	48	10	94	M12x1	1,54	1,5	30464599	30512766	30521103	MHC-HSK-A050-18-120-C-0-A-AAA2	30522839
	50	18	40	-	120	48	10	94	M12x1	4,52	2	30464599	30512762	30384303	MHC-HSK-A050-18-120-C-0-A-AAA3	30522840

Continued on next page.

2-channel system MQL hydraulic chucks HydroChuck | For automatic tool change, with axial tool length adjustment
Shank HSK-A in accordance with DIN 69893-1 | Available on request

Variant*	HSK-A	Dimensions							G	A _{IN}	sw	Components			Specification	Order No.
		d ₁	d ₂	d ₃	l ₁	l ₂	l ₃	l ₄				BDY	LS	CU		
	50	18	40	-	120	48	10	94	M12x1	9,9	3	30464599	30302857	30297305	MHC-HSK-A050-18-120-C-0-A-AAA2	30485306
	50	18	40	-	160	48	10	134	M12x1	1,54	1,5	30464607	30512780	30521103	MHC-HSK-A050-18-160-C-0-A-AAA3	30522865
	50	18	40	-	160	48	10	134	M12x1	4,52	2	30464607	30512776	30384303	MHC-HSK-A050-18-160-C-0-A-AAA2	30522866
	50	18	40	-	160	48	10	134	M12x1	9,9	3	30464607	30302865	30297305	MHC-HSK-A050-18-160-C-0-A-AAA3	30485322
	50	20	42	55	100	50	10	42	M16x1	4,52	2	30386548	30512798	30521103	MHC-HSK-A050-20-100-C-0-A-AAA1	30522815
	50	20	42	55	100	50	10	42	M16x1	9,9	3	30386548	30512795	30384303	MHC-HSK-A050-20-100-C-0-A-AAA2	30522816
	50	20	42	55	100	50	10	42	M16x1	17,35	4	30386548	30279429	30297305	MHC-HSK-A050-20-100-C-0-A-AAA3	30386268
	50	20	42	-	120	50	10	94	M16x1	4,52	2	30464600	30512768	30521103	MHC-HSK-A050-20-120-C-0-A-AAA2	30522841
	50	20	42	-	120	50	10	94	M16x1	9,9	3	30464600	30512767	30384303	MHC-HSK-A050-20-120-C-0-A-AAA3	30522842
	50	20	42	-	120	50	10	94	M16x1	17,35	4	30464600	30302858	30297305	MHC-HSK-A050-20-120-C-0-A-AAA2	30485307
	50	20	42	-	160	50	10	134	M16x1	4,52	2	30464608	30512782	30521103	MHC-HSK-A050-20-160-C-0-A-AAA3	30522867
	50	20	42	-	160	50	10	134	M16x1	9,9	3	30464608	30512781	30384303	MHC-HSK-A050-20-160-C-0-A-AAA2	30522868
	50	20	42	-	160	50	10	134	M16x1	17,35	4	30464608	30302866	30297305	MHC-HSK-A050-20-160-C-0-A-AAA3	30485323
	63	6	26	38	160	36	10	118,0	M5	1,54	1,5	30464617	30512819	30512203	MHC-HSK-A063-06-160-C-0-A-AAA1	30522942
	63	6	26	38	160	36	10	118,0	M5	4,52	2,0	30464617	30384041	30384304	MHC-HSK-A063-06-160-C-0-A-AAA2	30485348
	63	6	26	38	200	36	10	155,0	M5	1,54	1,5	30464627	30512839	30512203	MHC-HSK-A063-06-200-C-0-A-AAA1	30522976
	63	6	26	38	200	36	10	155,0	M5	4,52	2,0	30464627	30384042	30384304	MHC-HSK-A063-06-200-C-0-A-AAA2	30485368
	63	8	28	38	160	36	10	118,5	M7	1,54	1,5	30464618	30512820	30512203	MHC-HSK-A063-08-160-C-0-A-AAA1	30522943
	63	8	28	38	160	36	10	118,5	M7	4,52	2,0	30464618	30384045	30384304	MHC-HSK-A063-08-160-C-0-A-AAA2	30485349
	63	8	28	38	200	36	10	155,5	M7	1,54	1,5	30464628	30512840	30512203	MHC-HSK-A063-08-200-C-0-A-AAA1	30522977
	63	8	28	38	200	36	10	155,5	M7	4,52	2,0	30464628	30384046	30384304	MHC-HSK-A063-08-200-C-0-A-AAA2	30485369
	63	10	30	40	160	40	10	115,0	M8x1	1,54	1,5	30464619	30512821	30512203	MHC-HSK-A063-10-160-C-0-A-AAA1	30522944
	63	10	30	40	160	40	10	115,0	M8x1	4,52	2,0	30464619	30384013	30384304	MHC-HSK-A063-10-160-C-0-A-AAA2	30485350
	63	10	30	40	200	40	10	155,0	M8x1	1,54	1,5	30464629	30512841	30512203	MHC-HSK-A063-10-200-C-0-A-AAA1	30522978
	63	10	30	40	200	40	10	155,0	M8x1	4,52	2,0	30464629	30384014	30384304	MHC-HSK-A063-10-200-C-0-A-AAA2	30485370
	63	12	32	40	160	45	10	120,5	M10x1	1,54	1,5	30464620	30512826	30512203	MHC-HSK-A063-12-160-C-0-A-AAA1	30522945
	63	12	32	40	160	45	10	120,5	M10x1	4,52	2,0	30464620	30512822	30384304	MHC-HSK-A063-12-160-C-0-A-AAA2	30522946
	63	12	32	40	160	45	10	120,5	M10x1	9,90	3,0	30464620	30279404	30284772	MHC-HSK-A063-12-160-C-0-A-AAA3	30485351
	63	12	32	40	200	45	10	160,5	M10x1	1,54	1,5	30464630	30512846	30512203	MHC-HSK-A063-12-200-C-0-A-AAA1	30522979
	63	12	32	40	200	45	10	160,5	M10x1	4,52	2,0	30464630	30512842	30384304	MHC-HSK-A063-12-200-C-0-A-AAA2	30522980
	63	12	32	40	200	45	10	160,5	M10x1	9,90	3,0	30464630	30279405	30284772	MHC-HSK-A063-12-200-C-0-A-AAA3	30485371
	63	14	34	40	160	45	10	121,0	M10x1	1,54	1,5	30464621	30512827	30512203	MHC-HSK-A063-14-160-C-0-A-AAA1	30522947
	63	14	34	40	160	45	10	121,0	M10x1	4,52	2,0	30464621	30512823	30384304	MHC-HSK-A063-14-160-C-0-A-AAA2	30522948
	63	14	34	40	160	45	10	121,0	M10x1	9,90	3,0	30464621	30279410	30284772	MHC-HSK-A063-14-160-C-0-A-AAA3	30485352
	63	14	34	40	200	45	10	161,0	M10x1	1,54	1,5	30464631	30512847	30512203	MHC-HSK-A063-14-200-C-0-A-AAA1	30522981
	63	14	34	40	200	45	10	161,0	M10x1	4,52	2,0	30464631	30512843	30384304	MHC-HSK-A063-14-200-C-0-A-AAA2	30522982
	63	14	34	40	200	45	10	161,0	M10x1	9,90	3,0	30464631	30279412	30284772	MHC-HSK-A063-14-200-C-0-A-AAA3	30485372
	63	16	38	-	160	48	10	131,1	M12x1	1,54	1,5	30464622	30512828	30512203	MHC-HSK-A063-16-160-C-0-A-AAA1	30522949
	63	16	38	-	160	48	10	131,1	M12x1	4,52	2,0	30464622	30512824	30384304	MHC-HSK-A063-16-160-C-0-A-AAA2	30522950
	63	16	38	-	160	48	10	131,1	M12x1	9,90	3,0	30464622	30279416	30284772	MHC-HSK-A063-16-160-C-0-A-AAA3	30485353
	63	16	38	-	200	48	10	171,1	M12x1	1,54	1,5	30464632	30512848	30512203	MHC-HSK-A063-16-200-C-0-A-AAA1	30522983
	63	16	38	-	200	48	10	171,1	M12x1	4,52	2,0	30464632	30512844	30384304	MHC-HSK-A063-16-200-C-0-A-AAA2	30522984
	63	16	38	-	200	48	10	171,1	M12x1	9,90	3,0	30464632	30279418	30284772	MHC-HSK-A063-16-200-C-0-A-AAA3	30485373
	63	18	40	-	160	48	10	129,1	M12x1	1,54	1,5	30464623	30512829	30512203	MHC-HSK-A063-18-160-C-0-A-AAA1	30522951
	63	18	40	-	160	48	10	129,1	M12x1	4,52	2,0	30464623	30512825	30384304	MHC-HSK-A063-18-160-C-0-A-AAA2	30522952
	63	18	40	-	160	48	10	129,1	M12x1	9,90	3,0	30464623	30279423	30284772	MHC-HSK-A063-18-160-C-0-A-AAA3	30485354
	63	18	40	-	200	48	10	169,1	M12x1	1,54	1,5	30464633	30512849	30512203	MHC-HSK-A063-18-200-C-0-A-AAA1	30522985
	63	18	40	-	200	48	10	169,1	M12x1	4,52	2,0	30464633	30512845	30384304	MHC-HSK-A063-18-200-C-0-A-AAA2	30522986
	63	18	40	-	200	48	10	169,1	M12x1	9,90	3,0	30464633	30279427	30284772	MHC-HSK-A063-18-200-C-0-A-AAA3	30485374
	63	20	42	-	160	50	10	129,1	M16x1	4,52	2,0	30464624	30512833	30384304	MHC-HSK-A063-20-160-C-0-A-AAA1	30522953
	63	20	42	-	160	50	10	129,1	M16x1	9,90	3,0	30464624	30512830	30284772	MHC-HSK-A063-20-160-C-0-A-AAA2	30522954
	63	20	42	-	160	50	10	129,1	M16x1	17,35	4,0	30464624	30279432	30279444	MHC-HSK-A063-20-160-C-0-A-AAA3	30485355
	63	20	42	-	200	50	10	169,1	M16x1	4,52	2,0	30464634	30512853	30384304	MHC-HSK-A063-20-200-C-0-A-AAA1	30522987
	63	20	42	-	200	50	10	169,1	M16x1	9,90	3,0	30464634	30512850	30284772	MHC-HSK-A063-20-200-C-0-A-AAA2	30522988
	63	20	42	-	200	50	10	169,1	M16x1	17,35	4,0	30464634	30279433	30279444	MHC-HSK-A063-20-200-C-0-A-AAA3	30485375
	63	25	57	-	160	56	10	134,0	M16x1	4,52	2,0	30464625	30512834	30384304	MHC-HSK-A063-25-160-C-0-A-AAA1	30522955

2-channel system MQL hydraulic chucks HydroChuck | For automatic tool change, with axial tool length adjustment
Shank HSK-A in accordance with DIN 69893-1 | Available on request

Variant*	HSK-A	Dimensions							G	A _{IN}	sw	Components			Specification	Order No.
		d ₁	d ₂	d ₃	l ₁	l ₂	l ₃	l ₄				BDY	LS	CU		
	63	25	57	-	160	56	10	134,0	M16x1	9,90	3,0	30464625	30512831	30284772	MHC-HSK-A063-25-160-C-0-A-AAA2	30522956
	63	25	57	-	160	56	10	134,0	M16x1	17,35	4,0	30464625	30279435	30279444	MHC-HSK-A063-25-160-C-0-A-AAA3	30485356
	63	25	57	-	200	56	10	174,0	M16x1	4,52	2,0	30464635	30512854	30384304	MHC-HSK-A063-25-200-C-0-A-AAA1	30522989
	63	25	57	-	200	56	10	174,0	M16x1	9,90	3,0	30464635	30512851	30284772	MHC-HSK-A063-25-200-C-0-A-AAA2	30522990
	63	25	57	-	200	56	10	174,0	M16x1	17,35	4,0	30464635	30279436	30279444	MHC-HSK-A063-25-200-C-0-A-AAA3	30485376
	63	32	63	-	160	60	10	134,0	M16x1	4,52	2,0	30464626	30512835	30384304	MHC-HSK-A063-32-160-C-0-A-AAA1	30522957
	63	32	63	-	160	60	10	134,0	M16x1	9,90	3,0	30464626	30512832	30284772	MHC-HSK-A063-32-160-C-0-A-AAA2	30522958
	63	32	63	-	160	60	10	134,0	M16x1	17,35	4,0	30464626	30279442	30279444	MHC-HSK-A063-32-160-C-0-A-AAA3	30485357
	63	32	63	-	200	60	10	174,0	M16x1	4,52	2,0	30464636	30512856	30384304	MHC-HSK-A063-32-200-C-0-A-AAA1	30522991
	63	32	63	-	200	60	10	174,0	M16x1	9,90	3,0	30464636	30512852	30284772	MHC-HSK-A063-32-200-C-0-A-AAA2	30522992
	63	32	63	-	200	60	10	174,0	M16x1	17,35	4,0	30464636	30279443	30279444	MHC-HSK-A063-32-200-C-0-A-AAA3	30485377
	100	6	26	38	120	36	10	73,5	M5	1,54	1,5	30464665	30512804	30521106	MHC-HSK-A100-06-120-C-0-A-AAA1	30523172
	100	6	26	38	120	36	10	73,5	M5	4,52	2	30464665	30384040	30384306	MHC-HSK-A100-06-120-C-0-A-AAA2	30485444
	100	6	26	38	160	36	10	113,5	M5	1,54	1,5	30464673	30512819	30521106	MHC-HSK-A100-06-160-C-0-A-AAA1	30523198
	100	6	26	38	160	36	10	113,5	M5	4,52	2	30464673	30384041	30384306	MHC-HSK-A100-06-160-C-0-A-AAA2	30485460
	100	6	26	38	200	36	10	155	M5	1,54	1,5	30464683	30512839	30521106	MHC-HSK-A100-06-200-C-0-A-AAA1	30523232
	100	6	26	38	200	36	10	155	M5	4,52	2	30464683	30384042	30384306	MHC-HSK-A100-06-200-C-0-A-AAA2	30485480
	100	8	28	38	120	36	10	74	M7	1,54	1,5	30464666	30512805	30521106	MHC-HSK-A100-08-120-C-0-A-AAA1	30523173
	100	8	28	38	120	36	10	74	M7	4,52	2	30464666	30384044	30384306	MHC-HSK-A100-08-120-C-0-A-AAA2	30485445
	100	8	28	38	160	36	10	114	M7	1,54	1,5	30464674	30512820	30521106	MHC-HSK-A100-08-160-C-0-A-AAA1	30523199
	100	8	28	38	160	36	10	114	M7	4,52	2	30464674	30384045	30384306	MHC-HSK-A100-08-160-C-0-A-AAA2	30485461
	100	8	28	38	200	36	10	155,5	M7	1,54	1,5	30464684	30512840	30521106	MHC-HSK-A100-08-200-C-0-A-AAA1	30523233
	100	8	28	38	200	36	10	155,5	M7	4,52	2	30464684	30384046	30384306	MHC-HSK-A100-08-200-C-0-A-AAA2	30485481
	100	10	30	40	120	40	10	74,5	M8x1	1,54	1,5	30464667	30512806	30521106	MHC-HSK-A100-10-120-C-0-A-AAA1	30523174
	100	10	30	40	120	40	10	74,5	M8x1	4,52	2	30464667	30384012	30384306	MHC-HSK-A100-10-120-C-0-A-AAA2	30485446
	100	10	30	40	160	40	10	114,5	M8x1	1,54	1,5	30464675	30512821	30521106	MHC-HSK-A100-10-160-C-0-A-AAA1	30523200
	100	10	30	40	160	40	10	114,5	M8x1	4,52	2	30464675	30384013	30384306	MHC-HSK-A100-10-160-C-0-A-AAA2	30485462
	100	10	30	40	200	40	10	155	M8x1	1,54	1,5	30464685	30512841	30521106	MHC-HSK-A100-10-200-C-0-A-AAA1	30523234
	100	10	30	40	200	40	10	155	M8x1	4,52	2	30464685	30384014	30384306	MHC-HSK-A100-10-200-C-0-A-AAA2	30485482
	100	12	32	40	120	45	10	75	M10x1	1,54	1,5	30464668	30512811	30521106	MHC-HSK-A100-12-120-C-0-A-AAA1	30523175
	100	12	32	40	120	45	10	75	M10x1	4,52	2	30464668	30512807	30384306	MHC-HSK-A100-12-120-C-0-A-AAA2	30523176
	100	12	32	40	120	45	10	75	M10x1	9,9	3	30464668	30279402	30297309	MHC-HSK-A100-12-120-C-0-A-AAA3	30485447
	100	12	32	40	160	45	10	115	M10x1	1,54	1,5	30464676	30512826	30521106	MHC-HSK-A100-12-160-C-0-A-AAA1	30523201
	100	12	32	40	160	45	10	115	M10x1	4,52	2	30464676	30512822	30384306	MHC-HSK-A100-12-160-C-0-A-AAA2	30523202
	100	12	32	40	160	45	10	115	M10x1	9,9	3	30464676	30279404	30297309	MHC-HSK-A100-12-160-C-0-A-AAA3	30485463
	100	12	32	40	200	45	10	155	M10x1	1,54	1,5	30464686	30512846	30521106	MHC-HSK-A100-12-200-C-0-A-AAA1	30523235
	100	12	32	40	200	45	10	155	M10x1	4,52	2	30464686	30512842	30384306	MHC-HSK-A100-12-200-C-0-A-AAA2	30523236
	100	12	32	40	200	45	10	155	M10x1	9,9	3	30464686	30279405	30297309	MHC-HSK-A100-12-200-C-0-A-AAA3	30485483
	100	14	34	40	120	45	10	75,5	M10x1	1,54	1,5	30464669	30512813	30521106	MHC-HSK-A100-14-120-C-0-A-AAA1	30523177
	100	14	34	40	120	45	10	75,5	M10x1	4,52	2	30464669	30512808	30384306	MHC-HSK-A100-14-120-C-0-A-AAA2	30523178
	100	14	34	40	120	45	10	75,5	M10x1	9,9	3	30464669	30279408	30297309	MHC-HSK-A100-14-120-C-0-A-AAA3	30485448
	100	14	34	40	160	45	10	115,5	M10x1	1,54	1,5	30464677	30512827	30521106	MHC-HSK-A100-14-160-C-0-A-AAA1	30523203
	100	14	34	40	160	45	10	115,5	M10x1	4,52	2	30464677	30512823	30384306	MHC-HSK-A100-14-160-C-0-A-AAA2	30523204
	100	14	34	40	160	45	10	115,5	M10x1	9,9	3	30464677	30279410	30297309	MHC-HSK-A100-14-160-C-0-A-AAA3	30485464
	100	14	34	40	200	45	10	155,5	M10x1	1,54	1,5	30464687	30512847	30521106	MHC-HSK-A100-14-200-C-0-A-AAA1	30523237
	100	14	34	40	200	45	10	155,5	M10x1	4,52	2	30464687	30512843	30384306	MHC-HSK-A100-14-200-C-0-A-AAA2	30523238
	100	14	34	40	200	45	10	155,5	M10x1	9,9	3	30464687	30279412	30297309	MHC-HSK-A100-14-200-C-0-A-AAA3	30485484
	100	16	38	-	120	48	10	81,1	M12x1	1,54	1,5	30464670	30512814	30521106	MHC-HSK-A100-16-120-C-0-A-AAA1	30523179
	100	16	38	-	120	48	10	81,1	M12x1	4,52	2	30464670	30512809	30384306	MHC-HSK-A100-16-120-C-0-A-AAA2	30523180
	100	16	38	-	120	48	10	81,1	M12x1	9,9	3	30464670	30279414	30297309	MHC-HSK-A100-16-120-C-0-A-AAA3	30485449
	100	16	38	-	160	48	10	121,1	M12x1	1,54	1,5	30464678	30512828	30521106	MHC-HSK-A100-16-160-C-0-A-AAA1	30523205
	100	16	38	-	160	48	10	121,1	M12x1	4,52	2	30464678	30512824	30384306	MHC-HSK-A100-16-160-C-0-A-AAA2	30523206
	100	16	38	-	160	48	10	121,1	M12x1	9,9	3	30464678	30279416	30297309	MHC-HSK-A100-16-160-C-0-A-AAA3	30485465
	100	16	38	-	200	48	10	161,1	M12x1	1,54	1,5	30464688	30512848	30521106	MHC-HSK-A100-16-200-C-0-A-AAA1	30523239
	100	16	38	-	200	48	10	161,1	M12x1	4,52	2	30464688	30512844	30384306	MHC-HSK-A100-16-200-C-0-A-AAA2	30523240
	100	16	38	-	200	48	10	161,1	M12x1	9,9	3	30464688	30279418	30297309	MHC-HSK-A100-16-200-C-0-A-AAA3	30485485

2-channel system MQL hydraulic chucks HydroChuck | For automatic tool change, with axial tool length adjustment
Shank HSK-A in accordance with DIN 69893-1 | Available on request

Variant*	HSK-A	Dimensions							G	A _{IN}	sw	Components			Specification	Order No.
		d ₁	d ₂	d ₃	l ₁	l ₂	l ₃	l ₄				BDY	LS	CU		
	100	18	40	-	120	48	10	81,1	M12x1	1,54	1,5	30464671	30512815	30521106	MHC-HSK-A100-18-120-C-0-A-AAA1	30523181
	100	18	40	-	120	48	10	81,1	M12x1	4,52	2	30464671	30512810	30384306	MHC-HSK-A100-18-120-C-0-A-AAA2	30523182
	100	18	40	-	120	48	10	81,1	M12x1	9,9	3	30464671	30279422	30297309	MHC-HSK-A100-18-120-C-0-A-AAA3	30485450
	100	18	40	-	160	48	10	121,1	M12x1	1,54	1,5	30464679	30512829	30521106	MHC-HSK-A100-18-160-C-0-A-AAA1	30523207
	100	18	40	-	160	48	10	121,1	M12x1	4,52	2	30464679	30512825	30384306	MHC-HSK-A100-18-160-C-0-A-AAA2	30523208
	100	18	40	-	160	48	10	121,1	M12x1	9,9	3	30464679	30279423	30297309	MHC-HSK-A100-18-160-C-0-A-AAA3	30485466
	100	18	40	-	200	48	10	161,1	M12x1	1,54	1,5	30464689	30512849	30521106	MHC-HSK-A100-18-200-C-0-A-AAA1	30523241
	100	18	40	-	200	48	10	161,1	M12x1	4,52	2	30464689	30512845	30384306	MHC-HSK-A100-18-200-C-0-A-AAA2	30523242
	100	18	40	-	200	48	10	161,1	M12x1	9,9	3	30464689	30279427	30297309	MHC-HSK-A100-18-200-C-0-A-AAA3	30485486
	100	20	42	-	120	50	10	81,1	M16x1	4,52	2	30464672	30512817	30384306	MHC-HSK-A100-20-120-C-0-A-AAA1	30523183
	100	20	42	-	120	50	10	81,1	M16x1	9,9	3	30464672	30512816	30297309	MHC-HSK-A100-20-120-C-0-A-AAA2	30523184
	100	20	42	-	120	50	10	81,1	M16x1	17,35	4	30464672	30279430	30297310	MHC-HSK-A100-20-120-C-0-A-AAA3	30485451
	100	20	42	-	160	50	10	121,1	M16x1	4,52	2	30464680	30512833	30384306	MHC-HSK-A100-20-160-C-0-A-AAA1	30523209
	100	20	42	-	160	50	10	121,1	M16x1	9,9	3	30464680	30512830	30297309	MHC-HSK-A100-20-160-C-0-A-AAA2	30523210
	100	20	42	-	160	50	10	121,1	M16x1	17,35	4	30464680	30279432	30297310	MHC-HSK-A100-20-160-C-0-A-AAA3	30485467
	100	20	42	-	200	50	10	161,1	M16x1	4,52	2	30464690	30512853	30384306	MHC-HSK-A100-20-200-C-0-A-AAA1	30523243
	100	20	42	-	200	50	10	161,1	M16x1	9,9	3	30464690	30512850	30297309	MHC-HSK-A100-20-200-C-0-A-AAA2	30523244
	100	20	42	-	200	50	10	161,1	M16x1	17,35	4	30464690	30279433	30297310	MHC-HSK-A100-20-200-C-0-A-AAA3	30485487
	100	25	57	-	160	56	10	131	M16x1	4,52	2	30464681	30512834	30384306	MHC-HSK-A100-25-160-C-0-A-AAA1	30523211
	100	25	57	-	160	56	10	131	M16x1	9,9	3	30464681	30512831	30297309	MHC-HSK-A100-25-160-C-0-A-AAA2	30523212
	100	25	57	-	160	56	10	131	M16x1	17,35	4	30464681	30279435	30297310	MHC-HSK-A100-25-160-C-0-A-AAA3	30485468
	100	25	57	-	200	56	10	171	M16x1	4,52	2	30464691	30512854	30384306	MHC-HSK-A100-25-200-C-0-A-AAA1	30523245
	100	25	57	-	200	56	10	171	M16x1	9,9	3	30464691	30512851	30297309	MHC-HSK-A100-25-200-C-0-A-AAA2	30523246
	100	25	57	-	200	56	10	171	M16x1	17,35	4	30464691	30279436	30297310	MHC-HSK-A100-25-200-C-0-A-AAA3	30485488
	100	32	63	-	160	60	10	131	M16x1	4,52	2	30464682	30512835	30384306	MHC-HSK-A100-32-160-C-0-A-AAA1	30523213
	100	32	63	-	160	60	10	131	M16x1	9,9	3	30464682	30512832	30297309	MHC-HSK-A100-32-160-C-0-A-AAA2	30523214
	100	32	63	-	160	60	10	131	M16x1	17,35	4	30464682	30279442	30297310	MHC-HSK-A100-32-160-C-0-A-AAA3	30485469
	100	32	63	-	200	60	10	171	M16x1	4,52	2	30464692	30512856	30384306	MHC-HSK-A100-32-200-C-0-A-AAA1	30523247
	100	32	63	-	200	60	10	171	M16x1	9,9	3	30464692	30512852	30297309	MHC-HSK-A100-32-200-C-0-A-AAA2	30523248
	100	32	63	-	200	60	10	171	M16x1	17,35	4	30464692	30279443	30297310	MHC-HSK-A100-32-200-C-0-A-AAA3	30485489

* The exact determination of the variant can be found in the selection system 2-channel system chucks.
The preferred series is marked with a green .

Dimensions in mm.

Use: For clamping tools with smooth cylindrical shanks according to DIN 1835 Form A, DIN 6535 Form HA as well as with recesses according to DIN 1835 Form B, E and DIN 6535 Form HB, HE directly and without reducing sleeve in the clamping diameter. The clamping diameter is designed for a shank tolerance h6.

Items included: Tool body, length adjustment screw and coolant unit as assembly.
These components can also be ordered separately. (see table)

Design: Longest tool lives and highest manufacturing quality on usage of smooth cylindrical shanks in accordance with DIN 1835 Form A and DIN 6535 Form HA. With a projection length of 2.5 x D (max. 50 mm) radial run-out accuracy 3 µm. On usage of cylindrical shanks with angled clamping surface (Form E and Form HE) the accuracy may be affected.

Different versions with chip available on request.
Balancing value: G 2.5 at 25,000 min⁻¹ as delivered.

Notes

2-channel system MQL shrink chucks ThermoChuck

For automatic tool change, with axial tool length adjustment
Shank HSK-A in accordance with DIN 69893-1

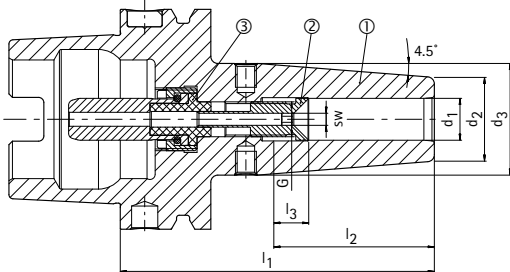

- ① Shrink chuck, HSK, MQL, tool body | BDY
- ② Length adjustment screw, MQL | LS
- ③ Coolant supply unit, MQL, automatic | CU



Preferred series in stock

Variant*	HSK-A	Dimensions						G	A _N	sw	Components			Specification	Order No.
		d ₁	d ₂	d ₃	l ₁	l ₂	l ₃				BDY	LS	CU		
	63	6	21	27	80	36	10	M10x1	1,54	1,5	10083235	30512784	30512203	MTC-HSK-A063-06-080-C-0-A-AAA1	30521882
	63	6	21	27	80	36	10	M10x1	4,52	2	10083235	30384039	30384304	MTC-HSK-A063-06-080-C-0-A-AAA2	30385638
	63	6	21	27	120	36	10	M5	1,54	1,5	30386128	30512804	30512203	MTC-HSK-A063-06-120-C-0-A-AAA1	30521884
	63	6	21	27	120	36	10	M5	4,52	2	30386128	30384040	30384304	MTC-HSK-A063-06-120-C-0-A-AAA2	30385658
	63	8	21	27	80	36	10	M10x1	1,54	1,5	10083236	30512785	30512203	MTC-HSK-A063-08-080-C-0-A-AAA1	30521890
	63	8	21	27	80	36	10	M10x1	4,52	2	10083236	30384043	30384304	MTC-HSK-A063-08-080-C-0-A-AAA2	30385639
	63	8	21	27	120	36	10	M7	1,54	1,5	30386129	30512805	30512203	MTC-HSK-A063-08-120-C-0-A-AAA1	30521892
	63	8	21	27	120	36	10	M7	4,52	2	30386129	30384044	30384304	MTC-HSK-A063-08-120-C-0-A-AAA2	30385659
	63	10	24	32	85	40	10	M10x1	1,54	1,5	10083237	30512786	30512203	MTC-HSK-A063-10-085-C-0-A-AAA1	30521898
	63	10	24	32	85	40	10	M10x1	4,52	2	10083237	30384011	30384304	MTC-HSK-A063-10-085-C-0-A-AAA2	30385640
	63	10	24	32	120	40	10	M8x1	1,54	1,5	30386800	30512806	30512203	MTC-HSK-A063-10-120-C-0-A-AAA1	30521900
	63	10	24	32	120	40	10	M8x1	4,52	2	30386800	30384012	30384304	MTC-HSK-A063-10-120-C-0-A-AAA2	30385660
	63	12	24	32	90	45	10	M10x1	1,54	1,5	10083238	30512791	30512203	MTC-HSK-A063-12-090-C-0-A-AAA1	30521906
	63	12	24	32	90	45	10	M10x1	4,52	2	10083238	30512787	30384304	MTC-HSK-A063-12-090-C-0-A-AAA2	30521908
	63	12	24	32	90	45	10	M10x1	9,9	3	10083238	30279400	30284772	MTC-HSK-A063-12-090-C-0-A-AAA3	30326631
	63	12	24	32	120	45	10	M10x1	1,54	1,5	10096023	30512811	30512203	MTC-HSK-A063-12-120-C-0-A-AAA1	30521910
	63	12	24	32	120	45	10	M10x1	4,52	2	10096023	30512807	30384304	MTC-HSK-A063-12-120-C-0-A-AAA2	30521912
	63	12	24	32	120	45	10	M10x1	9,9	3	10096023	30279402	30284772	MTC-HSK-A063-12-120-C-0-A-AAA3	30326641
	63	14	27	34	90	45	10	M10x1	1,54	1,5	10083239	30512792	30512203	MTC-HSK-A063-14-090-C-0-A-AAA1	30521922
	63	14	27	34	90	45	10	M10x1	4,52	2	10083239	30512788	30384304	MTC-HSK-A063-14-090-C-0-A-AAA2	30521924
	63	14	27	34	90	45	10	M10x1	9,9	3	10083239	30279407	30284772	MTC-HSK-A063-14-090-C-0-A-AAA3	30326632
	63	14	27	34	120	45	10	M10x1	1,54	1,5	30192712	30512813	30512203	MTC-HSK-A063-14-120-C-0-A-AAA1	30521926
	63	14	27	34	120	45	10	M10x1	4,52	2	30192712	30512808	30384304	MTC-HSK-A063-14-120-C-0-A-AAA2	30521928
	63	14	27	34	120	45	10	M10x1	9,9	3	30192712	30279408	30284772	MTC-HSK-A063-14-120-C-0-A-AAA3	30326642
	63	16	27	34	95	48	10	M12x1	1,54	1,5	10083240	30512793	30512203	MTC-HSK-A063-16-095-C-0-A-AAA1	30521938
	63	16	27	34	95	48	10	M12x1	4,52	2	10083240	30512789	30384304	MTC-HSK-A063-16-095-C-0-A-AAA2	30521940
	63	16	27	34	95	48	10	M12x1	9,9	3	10083240	30279413	30284772	MTC-HSK-A063-16-095-C-0-A-AAA3	30326633
	63	16	27	34	120	48	10	M12x1	1,54	1,5	10107287	30512814	30512203	MTC-HSK-A063-16-120-C-0-A-AAA1	30521942
	63	16	27	34	120	48	10	M12x1	4,52	2	10107287	30512809	30384304	MTC-HSK-A063-16-120-C-0-A-AAA2	30521944
	63	16	27	34	120	48	10	M12x1	9,9	3	10107287	30279414	30284772	MTC-HSK-A063-16-120-C-0-A-AAA3	30326643
	63	18	33	42	95	48	10	M12x1	1,54	1,5	10083241	30512794	30512203	MTC-HSK-A063-18-095-C-0-A-AAA1	30521954
	63	18	33	42	95	48	10	M12x1	4,52	2	10083241	30512790	30384304	MTC-HSK-A063-18-095-C-0-A-AAA2	30521956
	63	18	33	42	95	48	10	M12x1	9,9	3	10083241	30279420	30284772	MTC-HSK-A063-18-095-C-0-A-AAA3	30326634
	63	18	33	42	120	48	10	M12x1	1,54	1,5	10107292	30512815	30512203	MTC-HSK-A063-18-120-C-0-A-AAA1	30521958
	63	18	33	42	120	48	10	M12x1	4,52	2	10107292	30512810	30384304	MTC-HSK-A063-18-120-C-0-A-AAA2	30521960
	63	18	33	42	120	48	10	M12x1	9,9	3	10107292	30279422	30284772	MTC-HSK-A063-18-120-C-0-A-AAA3	30326644
	63	20	33	42	100	50	10	M16x1	4,52	2	10083242	30512798	30384304	MTC-HSK-A063-20-100-C-0-A-AAA2	30521970
	63	20	33	42	100	50	10	M16x1	9,9	3	10083242	30512795	30284772	MTC-HSK-A063-20-100-C-0-A-AAA3	30521972
	63	20	33	42	100	50	10	M16x1	17,35	4	10083242	30279429	30279444	MTC-HSK-A063-20-100-C-0-A-AAA4	30326635

2-channel system MQL shrink chucks ThermoChuck | For automatic tool change, with axial tool length adjustment
Shank HSK-A in accordance with DIN 69893-1 | Preferred series in stock

Variant*	HSK-A	Dimensions						G	A _N	sw	Components			Specification	Order No.
		d ₁	d ₂	d ₃	l ₁	l ₂	l ₃				BDY	LS	CU		
	63	20	33	42	120	50	10	M16x1	4,52	2	30192716	30512817	30384304	MTC-HSK-A063-20-120-C-0-A-AAA2	30521974
	63	20	33	42	120	50	10	M16x1	9,9	3	30192716	30512816	30284772	MTC-HSK-A063-20-120-C-0-A-AAA3	30521976
	63	20	33	42	120	50	10	M16x1	17,35	4	30192716	30279430	30279444	MTC-HSK-A063-20-120-C-0-A-AAA4	30326645
	63	25	44	53	115	56	10	M16x1	4,52	2	10083243	30512799	30384304	MTC-HSK-A063-25-115-C-0-A-AAA2	30521986
	63	25	44	53	115	56	10	M16x1	9,9	3	10083243	30512796	30284772	MTC-HSK-A063-25-115-C-0-A-AAA3	30521988
	63	25	44	53	115	56	10	M16x1	17,35	4	10083243	30279434	30279444	MTC-HSK-A063-25-115-C-0-A-AAA4	30326636
	63	32	44	53	120	60	10	M16x1	4,52	2	10083244	30512800	30384304	MTC-HSK-A063-32-120-C-0-A-AAA2	30521998
	63	32	44	53	120	60	10	M16x1	9,9	3	10083244	30512797	30284772	MTC-HSK-A063-32-120-C-0-A-AAA3	30522000
	63	32	44	53	120	60	10	M16x1	17,35	4	10083244	30279441	30279444	MTC-HSK-A063-32-120-C-0-A-AAA4	30326637
	100	6	21	27	85	36	10	M10x1	1,54	1,5	10083255	30512784	30521106	MTC-HSK-A100-06-085-C-0-A-AAA1	30522138
	100	6	21	27	85	36	10	M10x1	4,52	2	10083255	30384039	30384306	MTC-HSK-A100-06-085-C-0-A-AAA2	30385790
	100	8	21	27	85	36	10	M10x1	1,54	1,5	10083256	30512785	30521106	MTC-HSK-A100-08-085-C-0-A-AAA1	30522146
	100	8	21	27	85	36	10	M10x1	4,52	2	10083256	30384043	30384306	MTC-HSK-A100-08-085-C-0-A-AAA2	30385791
	100	10	24	32	90	40	10	M10x1	1,54	1,5	10083257	30512786	30521106	MTC-HSK-A100-10-090-C-0-A-AAA1	30522154
	100	10	24	32	90	40	10	M10x1	4,52	2	10083257	30384011	30384306	MTC-HSK-A100-10-090-C-0-A-AAA2	30385792
	100	12	24	32	95	45	10	M10x1	1,54	1,5	10083258	30512791	30521106	MTC-HSK-A100-12-095-C-0-A-AAA1	30522162
	100	12	24	32	95	45	10	M10x1	4,52	2	10083258	30512787	30384306	MTC-HSK-A100-12-095-C-0-A-AAA2	30522164
	100	12	24	32	95	45	10	M10x1	9,9	3	10083258	30279400	30297309	MTC-HSK-A100-12-095-C-0-A-AAA3	30326784
	100	14	27	34	95	45	10	M10x1	1,54	1,5	10083259	30512792	30521106	MTC-HSK-A100-14-095-C-0-A-AAA1	30522178
	100	14	27	34	95	45	10	M10x1	4,52	2	10083259	30512788	30384306	MTC-HSK-A100-14-095-C-0-A-AAA2	30522180
	100	14	27	34	95	45	10	M10x1	9,9	3	10083259	30279407	30297309	MTC-HSK-A100-14-095-C-0-A-AAA3	30326785
	100	16	27	34	100	48	10	M12x1	1,54	1,5	10083260	30512793	30521106	MTC-HSK-A100-16-100-C-0-A-AAA1	30522194
	100	16	27	34	100	48	10	M12x1	4,52	2	10083260	30512789	30384306	MTC-HSK-A100-16-100-C-0-A-AAA2	30522196
	100	16	27	34	100	48	10	M12x1	9,9	3	10083260	30279413	30297309	MTC-HSK-A100-16-100-C-0-A-AAA3	30326786
	100	18	33	42	100	48	10	M12x1	1,54	1,5	10083261	30512794	30521106	MTC-HSK-A100-18-100-C-0-A-AAA1	30522210
	100	18	33	42	100	48	10	M12x1	4,52	2	10083261	30512790	30384306	MTC-HSK-A100-18-100-C-0-A-AAA2	30522212
	100	18	33	42	100	48	10	M12x1	9,9	3	10083261	30279420	30297309	MTC-HSK-A100-18-100-C-0-A-AAA3	30326787
	100	20	33	42	105	50	10	M16x1	4,52	2	10083262	30512798	30384306	MTC-HSK-A100-20-105-C-0-A-AAA2	30522226
	100	20	33	42	105	50	10	M16x1	9,9	3	10083262	30512795	30297309	MTC-HSK-A100-20-105-C-0-A-AAA3	30522228
	100	20	33	42	105	50	10	M16x1	17,35	4	10083262	30279429	30297310	MTC-HSK-A100-20-105-C-0-A-AAA4	30326788
	100	25	44	53	115	56	10	M16x1	4,52	2	10083263	30512799	30384306	MTC-HSK-A100-25-115-C-0-A-AAA2	30522242
	100	25	44	53	115	56	10	M16x1	9,9	3	10083263	30512796	30297309	MTC-HSK-A100-25-115-C-0-A-AAA3	30522244
	100	25	44	53	115	56	10	M16x1	17,35	4	10083263	30279434	30297310	MTC-HSK-A100-25-115-C-0-A-AAA4	30326789
	100	32	44	53	120	60	10	M16x1	4,52	2	10083264	30512800	30384306	MTC-HSK-A100-32-120-C-0-A-AAA2	30522254
	100	32	44	53	120	60	10	M16x1	9,9	3	10083264	30512797	30297309	MTC-HSK-A100-32-120-C-0-A-AAA3	30522256
	100	32	44	53	120	60	10	M16x1	17,35	4	10083264	30279441	30297310	MTC-HSK-A100-32-120-C-0-A-AAA4	30326790

* The exact determination of the variant can be found in the selection system 2-channel system chucks.

The preferred series is marked with a green .

Dimensions in mm.

Items included: Tool body, length adjustment screw and coolant unit as assembly. These components can also be ordered separately. (see table)"

Design: Permissible run-out deviation on the hollow taper shank in relation to the clamping diameter d₁ = 3 µm. The clamping diameter is designed for a shank tolerance of h6.

Different versions with chip available on request.

Balancing value: G 2.5 at 25,000 min⁻¹ as delivered.

2-channel system MQL shrink chucks ThermoChuck

For automatic tool change, with axial tool length adjustment
Shank HSK-A in accordance with DIN 69893-1

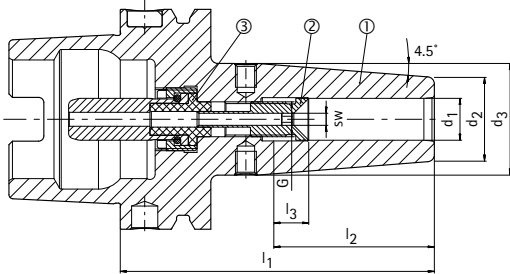

- ① Shrink chuck, HSK, MQL, tool body | BDY
- ② Length adjustment screw, MQL | LS
- ③ Coolant supply unit, MQL, automatic | CU



Available on request

Variant*	HSK-A	Dimensions						G	A _N mm ²	sw	Components			Specification	Order No.
		d ₁	d ₂	d ₃	l ₁	l ₂	l ₃				BDY	LS	CU		
	40	6	21	27	80	36	10	M7	1,54	1,5	10083221	30512726	30521102	MTC-HSK-A040-06-080-C-0-A-AAA1	30521750
	40	6	21	27	80	36	10	M7	4,52	2	10083221	30383971	30384302	MTC-HSK-A040-06-080-C-0-A-AAA2	30385554
	40	8	21	27	80	36	10	M7	1,54	1,5	10083222	30512727	30521102	MTC-HSK-A040-08-080-C-0-A-AAA1	30521756
	40	8	21	27	80	36	10	M7	4,52	2	10083222	30383974	30384302	MTC-HSK-A040-08-080-C-0-A-AAA2	30385555
	40	10	24	32	80	40	10	M8x1	1,54	1,5	10083223	30512728	30521102	MTC-HSK-A040-10-080-C-0-A-AAA1	30521762
	40	10	24	32	80	40	10	M8x1	4,52	2	10083223	30383959	30384302	MTC-HSK-A040-10-080-C-0-A-AAA2	30385556
	40	12	24	32	90	45	10	M10x1	1,54	1,5	10083224	30512732	30521102	MTC-HSK-A040-12-090-C-0-A-AAA1	30521768
	40	12	24	32	90	45	10	M10x1	4,52	2	10083224	30512729	30384302	MTC-HSK-A040-12-090-C-0-A-AAA2	30521770
	40	12	24	32	90	45	10	M10x1	9,9	3	10083224	30280050	30297304	MTC-HSK-A040-12-090-C-0-A-AAA3	30326547
	40	14	27	34	90	45	10	M10x1	1,54	1,5	10083225	30512733	30521102	MTC-HSK-A040-14-090-C-0-A-AAA1	30521780
	40	14	27	34	90	45	10	M10x1	4,52	2	10083225	30512730	30384302	MTC-HSK-A040-14-090-C-0-A-AAA2	30521782
	40	14	27	34	90	45	10	M10x1	9,9	3	10083225	30280051	30297304	MTC-HSK-A040-14-090-C-0-A-AAA3	30326548
	40	16	27	34	90	48	10	M12x1	1,54	1,5	10083226	30512734	30521102	MTC-HSK-A040-16-090-C-0-A-AAA1	30521792
	40	16	27	34	90	48	10	M12x1	4,52	2	10083226	30512731	30384302	MTC-HSK-A040-16-090-C-0-A-AAA2	30521794
	40	16	27	34	90	48	10	M12x1	9,9	3	10083226	30280052	30297304	MTC-HSK-A040-16-090-C-0-A-AAA3	30326549
	50	6	21	27	80	36	10	M8x1	1,54	1,5	10083227	30512753	30521103	MTC-HSK-A050-06-080-C-0-A-AAA1	30521804
	50	6	21	27	80	36	10	M8x1	4,52	2	10083227	30384009	30384303	MTC-HSK-A050-06-080-C-0-A-AAA2	30385590
	50	8	21	27	80	36	10	M8x1	1,54	1,5	10083228	30512754	30521103	MTC-HSK-A050-08-080-C-0-A-AAA1	30521810
	50	8	21	27	80	36	10	M8x1	4,52	2	10083228	30384010	30384303	MTC-HSK-A050-08-080-C-0-A-AAA2	30385591
	50	10	24	32	85	40	10	M8x1	1,54	1,5	10083229	30512755	30521103	MTC-HSK-A050-10-085-C-0-A-AAA1	30521816
	50	10	24	32	85	40	10	M8x1	4,52	2	10083229	30384004	30384303	MTC-HSK-A050-10-085-C-0-A-AAA2	30385592
	50	12	24	32	90	45	10	M10x1	1,54	1,5	10083230	30512791	30521103	MTC-HSK-A050-12-090-C-0-A-AAA1	30521822
	50	12	24	32	90	45	10	M10x1	4,52	2	10083230	30512787	30384303	MTC-HSK-A050-12-090-C-0-A-AAA2	30521824
	50	12	24	32	90	45	10	M10x1	9,9	3	10083230	30279400	30297305	MTC-HSK-A050-12-090-C-0-A-AAA3	30326583
	50	14	27	34	90	45	10	M10x1	1,54	1,5	10083231	30512792	30521103	MTC-HSK-A050-14-090-C-0-A-AAA1	30521834
	50	14	27	34	90	45	10	M10x1	4,52	2	10083231	30512788	30384303	MTC-HSK-A050-14-090-C-0-A-AAA2	30521836
	50	14	27	34	90	45	10	M10x1	9,9	3	10083231	30279407	30297305	MTC-HSK-A050-14-090-C-0-A-AAA3	30326584
	50	16	27	34	95	48	10	M12x1	1,54	1,5	10083232	30512793	30521103	MTC-HSK-A050-16-095-C-0-A-AAA1	30521846
	50	16	27	34	95	48	10	M12x1	4,52	2	10083232	30512789	30384303	MTC-HSK-A050-16-095-C-0-A-AAA2	30521848
	50	16	27	34	95	48	10	M12x1	9,9	3	10083232	30279413	30297305	MTC-HSK-A050-16-095-C-0-A-AAA3	30326585
	50	18	33	42	95	48	10	M12x1	1,54	1,5	10083233	30512794	30521103	MTC-HSK-A050-18-095-C-0-A-AAA1	30521858
	50	18	33	42	95	48	10	M12x1	4,52	2	10083233	30512790	30384303	MTC-HSK-A050-18-095-C-0-A-AAA2	30521860
	50	18	33	42	95	48	10	M12x1	9,9	3	10083233	30279420	30297305	MTC-HSK-A050-18-095-C-0-A-AAA3	30326586
	50	20	33	42	100	50	10	M16x1	4,52	2	10083234	30512798	30384303	MTC-HSK-A050-20-100-C-0-A-AAA2	30521870
	50	20	33	42	100	50	10	M16x1	9,9	3	10083234	30512795	30297305	MTC-HSK-A050-20-100-C-0-A-AAA3	30521872
	50	20	33	42	100	50	10	M16x1	17,35	4	10083234	30279429	30297306	MTC-HSK-A050-20-100-C-0-A-AAA4	30326587
	63	6	21	27	160	36	10	M5	1,54	1,5	30386130	30512819	30512203	MTC-HSK-A063-06-160-C-0-A-AAA1	30521886
	63	6	21	27	160	36	10	M5	4,52	2,0	30386130	30384041	30384304	MTC-HSK-A063-06-160-C-0-A-AAA2	30385674
	63	6	21	27	200	36	10	M5	1,54	1,5	30386132	30512839	30512203	MTC-HSK-A063-06-200-C-0-A-AAA1	30521888

2-channel system MQL shrink chucks ThermoChuck | For automatic tool change, with axial tool length adjustment
Shank HSK-A in accordance with DIN 69893-1 | Available on request

Variant*	HSK-A	Dimensions						G	A _{IN}	sw	Components			Specification	Order No.
		d ₁	d ₂	d ₃	l ₁	l ₂	l ₃				BDY	LS	CU		
	63	6	21	27	200	36	10	M5	4,52	2,0	30386132	30384042	30384304	MTC-HSK-A063-06-200-C-0-A-AAA2	30385694
	63	8	21	27	160	36	10	M7	1,54	1,5	30386131	30512820	30512203	MTC-HSK-A063-08-160-C-0-A-AAA1	30521894
	63	8	21	27	160	36	10	M7	4,52	2,0	30386131	30384045	30384304	MTC-HSK-A063-08-160-C-0-A-AAA2	30385675
	63	8	21	27	200	36	10	M7	1,54	1,5	30386133	30512840	30512203	MTC-HSK-A063-08-200-C-0-A-AAA1	30521896
	63	8	21	27	200	36	10	M7	4,52	2,0	30386133	30384046	30384304	MTC-HSK-A063-08-200-C-0-A-AAA2	30385695
	63	10	24	32	160	40	10	M8x1	1,54	1,5	30386802	30512821	30512203	MTC-HSK-A063-10-160-C-0-A-AAA1	30521902
	63	10	24	32	160	40	10	M8x1	4,52	2,0	30386802	30384013	30384304	MTC-HSK-A063-10-160-C-0-A-AAA2	30385676
	63	10	24	32	200	40	10	M8x1	1,54	1,5	30386134	30512841	30512203	MTC-HSK-A063-10-200-C-0-A-AAA1	30521904
	63	10	24	32	200	40	10	M8x1	4,52	2,0	30386134	30384014	30384304	MTC-HSK-A063-10-200-C-0-A-AAA2	30385696
	63	12	24	32	160	45	10	M10x1	1,54	1,5	30197953	30512826	30512203	MTC-HSK-A063-12-160-C-0-A-AAA1	30521914
	63	12	24	32	160	45	10	M10x1	4,52	2,0	30197953	30512822	30384304	MTC-HSK-A063-12-160-C-0-A-AAA2	30521916
	63	12	24	32	160	45	10	M10x1	9,90	3,0	30197953	30279404	30284772	MTC-HSK-A063-12-160-C-0-A-AAA3	30326649
	63	12	24	32	200	45	10	M10x1	1,54	1,5	10107285	30512846	30512203	MTC-HSK-A063-12-200-C-0-A-AAA1	30521918
	63	12	24	32	200	45	10	M10x1	4,52	2,0	10107285	30512842	30384304	MTC-HSK-A063-12-200-C-0-A-AAA2	30521920
	63	12	24	32	200	45	10	M10x1	9,90	3,0	10107285	30279405	30284772	MTC-HSK-A063-12-200-C-0-A-AAA3	30326659
	63	14	27	34	160	45	10	M10x1	1,54	1,5	10096025	30512827	30512203	MTC-HSK-A063-14-160-C-0-A-AAA1	30521930
	63	14	27	34	160	45	10	M10x1	4,52	2,0	10096025	30512823	30384304	MTC-HSK-A063-14-160-C-0-A-AAA2	30521932
	63	14	27	34	160	45	10	M10x1	9,90	3,0	10096025	30279410	30284772	MTC-HSK-A063-14-160-C-0-A-AAA3	30326650
	63	14	27	34	200	45	10	M10x1	1,54	1,5	10096026	30512847	30512203	MTC-HSK-A063-14-200-C-0-A-AAA1	30521934
	63	14	27	34	200	45	10	M10x1	4,52	2,0	10096026	30512843	30384304	MTC-HSK-A063-14-200-C-0-A-AAA2	30521936
	63	14	27	34	200	45	10	M10x1	9,90	3,0	10096026	30279412	30284772	MTC-HSK-A063-14-200-C-0-A-AAA3	30326660
	63	16	27	34	160	48	10	M12x1	1,54	1,5	10107288	30512828	30512203	MTC-HSK-A063-16-160-C-0-A-AAA1	30521946
	63	16	27	34	160	48	10	M12x1	4,52	2,0	10107288	30512824	30384304	MTC-HSK-A063-16-160-C-0-A-AAA2	30521948
	63	16	27	34	160	48	10	M12x1	9,90	3,0	10107288	30279416	30284772	MTC-HSK-A063-16-160-C-0-A-AAA3	30326651
	63	16	27	34	200	48	10	M12x1	1,54	1,5	10107289	30512848	30512203	MTC-HSK-A063-16-200-C-0-A-AAA1	30521950
	63	16	27	34	200	48	10	M12x1	4,52	2,0	10107289	30512844	30384304	MTC-HSK-A063-16-200-C-0-A-AAA2	30521952
	63	16	27	34	200	48	10	M12x1	9,90	3,0	10107289	30279418	30284772	MTC-HSK-A063-16-200-C-0-A-AAA3	30326661
	63	18	33	42	160	48	10	M12x1	1,54	1,5	10096027	30512829	30512203	MTC-HSK-A063-18-160-C-0-A-AAA1	30521962
	63	18	33	42	160	48	10	M12x1	4,52	2,0	10096027	30512825	30384304	MTC-HSK-A063-18-160-C-0-A-AAA2	30521964
	63	18	33	42	160	48	10	M12x1	9,90	3,0	10096027	30279423	30284772	MTC-HSK-A063-18-160-C-0-A-AAA3	30326652
	63	18	33	42	200	48	10	M12x1	1,54	1,5	10107293	30512849	30512203	MTC-HSK-A063-18-200-C-0-A-AAA1	30521966
	63	18	33	42	200	48	10	M12x1	4,52	2,0	10107293	30512845	30384304	MTC-HSK-A063-18-200-C-0-A-AAA2	30521968
	63	18	33	42	200	48	10	M12x1	9,90	3,0	10107293	30279427	30284772	MTC-HSK-A063-18-200-C-0-A-AAA3	30326662
	63	20	33	42	160	50	10	M16x1	4,52	2,0	10107294	30512833	30384304	MTC-HSK-A063-20-160-C-0-A-AAA2	30521978
	63	20	33	42	160	50	10	M16x1	9,90	3,0	10107294	30512830	30284772	MTC-HSK-A063-20-160-C-0-A-AAA3	30521980
	63	20	33	42	160	50	10	M16x1	17,35	4,0	10107294	30279432	30279444	MTC-HSK-A063-20-160-C-0-A-AAA4	30326653
	63	20	33	42	200	50	10	M16x1	4,52	2,0	10107295	30512853	30384304	MTC-HSK-A063-20-200-C-0-A-AAA2	30521982
	63	20	33	42	200	50	10	M16x1	9,90	3,0	10107295	30512850	30284772	MTC-HSK-A063-20-200-C-0-A-AAA3	30521984
	63	20	33	42	200	50	10	M16x1	17,35	4,0	10107295	30279433	30279444	MTC-HSK-A063-20-200-C-0-A-AAA4	30326663
	63	25	44	53	160	56	10	M16x1	4,52	2,0	10107296	30512834	30384304	MTC-HSK-A063-25-160-C-0-A-AAA2	30521990
	63	25	44	53	160	56	10	M16x1	9,90	3,0	10107296	30512831	30284772	MTC-HSK-A063-25-160-C-0-A-AAA3	30521992
	63	25	44	53	160	56	10	M16x1	17,35	4,0	10107296	30279435	30279444	MTC-HSK-A063-25-160-C-0-A-AAA4	30326654
	63	25	44	53	200	56	10	M16x1	4,52	2,0	10107297	30512854	30384304	MTC-HSK-A063-25-200-C-0-A-AAA2	30521994
	63	25	44	53	200	56	10	M16x1	9,90	3,0	10107297	30512851	30284772	MTC-HSK-A063-25-200-C-0-A-AAA3	30521996
	63	25	44	53	200	56	10	M16x1	17,35	4,0	10107297	30279436	30279444	MTC-HSK-A063-25-200-C-0-A-AAA4	30326664
	63	32	44	53	160	60	10	M16x1	4,52	2,0	10107298	30512835	30384304	MTC-HSK-A063-32-160-C-0-A-AAA2	30522002
	63	32	44	53	160	60	10	M16x1	9,90	3,0	10107298	30512832	30284772	MTC-HSK-A063-32-160-C-0-A-AAA3	30522004
	63	32	44	53	160	60	10	M16x1	17,35	4,0	10107298	30279442	30279444	MTC-HSK-A063-32-160-C-0-A-AAA4	30326655
	63	32	44	53	200	60	10	M16x1	4,52	2,0	10107299	30512856	30384304	MTC-HSK-A063-32-200-C-0-A-AAA2	30522006
	63	32	44	53	200	60	10	M16x1	9,90	3,0	10107299	30512852	30284772	MTC-HSK-A063-32-200-C-0-A-AAA3	30522008
	63	32	44	53	200	60	10	M16x1	17,35	4,0	10107299	30279443	30279444	MTC-HSK-A063-32-200-C-0-A-AAA4	30326665
	80	6	21	27	85	36	10	M10x1	1,54	1,5	10083245	30512784	30521104	MTC-HSK-A080-06-085-C-0-A-AAA1	30522010
	80	6	21	27	85	36	10	M10x1	4,52	2	10083245	30384039	30384305	MTC-HSK-A080-06-085-C-0-A-AAA2	30385714
	80	8	21	27	85	36	10	M10x1	1,54	1,5	10083246	30512785	30521104	MTC-HSK-A080-08-085-C-0-A-AAA1	30522018
	80	8	21	27	85	36	10	M10x1	4,52	2	10083246	30384043	30384305	MTC-HSK-A080-08-085-C-0-A-AAA2	30385715
	80	10	24	32	90	40	10	M10x1	1,54	1,5	10083247	30512786	30521104	MTC-HSK-A080-10-090-C-0-A-AAA1	30522026

Continued on next page.

2-channel system MQL shrink chucks ThermoChuck | For automatic tool change, with axial tool length adjustment
Shank HSK-A in accordance with DIN 69893-1 | Available on request

Variant*	HSK-A	Dimensions						G	A _N mm ²	sw	Components			Specification	Order No.
		d ₁	d ₂	d ₃	l ₁	l ₂	l ₃				BDY	LS	CU		
	80	10	24	32	90	40	10	M10x1	4,52	2	10083247	30384011	30384305	MTC-HSK-A080-10-090-C-0-A-AAA2	30385716
	80	12	24	32	95	45	10	M10x1	1,54	1,5	10083248	30512791	30521104	MTC-HSK-A080-12-095-C-0-A-AAA1	30522034
	80	12	24	32	95	45	10	M10x1	4,52	2	10083248	30512787	30384305	MTC-HSK-A080-12-095-C-0-A-AAA2	30522036
	80	12	24	32	95	45	10	M10x1	9,9	3	10083248	30279400	30297307	MTC-HSK-A080-12-095-C-0-A-AAA3	30326708
	80	14	27	34	95	45	10	M10x1	1,54	1,5	10083249	30512792	30521104	MTC-HSK-A080-14-095-C-0-A-AAA1	30522050
	80	14	27	34	95	45	10	M10x1	4,52	2	10083249	30512788	30384305	MTC-HSK-A080-14-095-C-0-A-AAA2	30522052
	80	14	27	34	95	45	10	M10x1	9,9	3	10083249	30279407	30297307	MTC-HSK-A080-14-095-C-0-A-AAA3	30326709
	80	16	27	34	100	48	10	M12x1	1,54	1,5	10083250	30512793	30521104	MTC-HSK-A080-16-100-C-0-A-AAA1	30522066
	80	16	27	34	100	48	10	M12x1	4,52	2	10083250	30512789	30384305	MTC-HSK-A080-16-100-C-0-A-AAA2	30522068
	80	16	27	34	100	48	10	M12x1	9,9	3	10083250	30279413	30297307	MTC-HSK-A080-16-100-C-0-A-AAA3	30326710
	80	18	33	42	100	48	10	M12x1	1,54	1,5	10083251	30512794	30521104	MTC-HSK-A080-18-100-C-0-A-AAA1	30522082
	80	18	33	42	100	48	10	M12x1	4,52	2	10083251	30512790	30384305	MTC-HSK-A080-18-100-C-0-A-AAA2	30522084
	80	18	33	42	100	48	10	M12x1	9,9	3	10083251	30279420	30297307	MTC-HSK-A080-18-100-C-0-A-AAA3	30326711
	80	20	33	42	105	50	10	M16x1	4,52	2	10083252	30512798	30384305	MTC-HSK-A080-20-105-C-0-A-AAA2	30522098
	80	20	33	42	105	50	10	M16x1	9,9	3	10083252	30512795	30297307	MTC-HSK-A080-20-105-C-0-A-AAA3	30522100
	80	20	33	42	105	50	10	M16x1	17,35	4	10083252	30279429	30297308	MTC-HSK-A080-20-105-C-0-A-AAA4	30326712
	80	25	44	53	115	56	10	M16x1	4,52	2	10083253	30512799	30384305	MTC-HSK-A080-25-115-C-0-A-AAA2	30522114
	80	25	44	53	115	56	10	M16x1	9,9	3	10083253	30512796	30297307	MTC-HSK-A080-25-115-C-0-A-AAA3	30522116
	80	25	44	53	115	56	10	M16x1	17,35	4	10083253	30279434	30297308	MTC-HSK-A080-25-115-C-0-A-AAA4	30326713
	80	32	44	53	120	60	10	M16x1	4,52	2	10083254	30512800	30384305	MTC-HSK-A080-32-120-C-0-A-AAA2	30522126
	80	32	44	53	120	60	10	M16x1	9,9	3	10083254	30512797	30297307	MTC-HSK-A080-32-120-C-0-A-AAA3	30522128
	80	32	44	53	120	60	10	M16x1	17,35	4	10083254	30279441	30297308	MTC-HSK-A080-32-120-C-0-A-AAA4	30326714
	100	6	21	27	120	36	10	M5	1,54	1,5	30386144	30512804	30521106	MTC-HSK-A100-06-120-C-0-A-AAA1	30522140
	100	6	21	27	120	36	10	M5	4,52	2	30386144	30384040	30384306	MTC-HSK-A100-06-120-C-0-A-AAA2	30385810
	100	6	21	27	160	36	10	M5	1,54	1,5	30386147	30512819	30521106	MTC-HSK-A100-06-160-C-0-A-AAA1	30522142
	100	6	21	27	160	36	10	M5	4,52	2	30386147	30384041	30384306	MTC-HSK-A100-06-160-C-0-A-AAA2	30385826
	100	6	21	27	200	36	10	M5	1,54	1,5	30386150	30512839	30521106	MTC-HSK-A100-06-200-C-0-A-AAA1	30522144
	100	6	21	27	200	36	10	M5	4,52	2	30386150	30384042	30384306	MTC-HSK-A100-06-200-C-0-A-AAA2	30385847
	100	8	21	27	120	36	10	M7	1,54	1,5	30386145	30512805	30521106	MTC-HSK-A100-08-120-C-0-A-AAA1	30522148
	100	8	21	27	120	36	10	M7	4,52	2	30386145	30384044	30384306	MTC-HSK-A100-08-120-C-0-A-AAA2	30385811
	100	8	21	27	160	36	10	M7	1,54	1,5	30386148	30512820	30521106	MTC-HSK-A100-08-160-C-0-A-AAA1	30522150
	100	8	21	27	160	36	10	M7	4,52	2	30386148	30384045	30384306	MTC-HSK-A100-08-160-C-0-A-AAA2	30385827
	100	8	21	27	200	36	10	M7	1,54	1,5	30386151	30512840	30521106	MTC-HSK-A100-08-200-C-0-A-AAA1	30522152
	100	8	21	27	200	36	10	M7	4,52	2	30386151	30384046	30384306	MTC-HSK-A100-08-200-C-0-A-AAA2	30385848
	100	10	24	32	120	40	10	M8x1	1,54	1,5	30386146	30512806	30521106	MTC-HSK-A100-10-120-C-0-A-AAA1	30522156
	100	10	24	32	120	40	10	M8x1	4,52	2	30386146	30384012	30384306	MTC-HSK-A100-10-120-C-0-A-AAA2	30385812
	100	10	24	32	160	40	10	M8x1	1,54	1,5	30386149	30512821	30521106	MTC-HSK-A100-10-160-C-0-A-AAA1	30522158
	100	10	24	32	160	40	10	M8x1	4,52	2	30386149	30384013	30384306	MTC-HSK-A100-10-160-C-0-A-AAA2	30385828
	100	10	24	32	200	40	10	M8x1	1,54	1,5	30386152	30512841	30521106	MTC-HSK-A100-10-200-C-0-A-AAA1	30522160
	100	10	24	32	200	40	10	M8x1	4,52	2	30386152	30384014	30384306	MTC-HSK-A100-10-200-C-0-A-AAA2	30385849
	100	12	24	32	120	45	10	M10x1	1,54	1,5	30253151	30512811	30521106	MTC-HSK-A100-12-120-C-0-A-AAA1	30522166
	100	12	24	32	120	45	10	M10x1	4,52	2	30253151	30512807	30384306	MTC-HSK-A100-12-120-C-0-A-AAA2	30522168
	100	12	24	32	120	45	10	M10x1	9,9	3	30253151	30279402	30297309	MTC-HSK-A100-12-120-C-0-A-AAA3	30326794
	100	12	24	32	160	45	10	M10x1	1,54	1,5	30302825	30512826	30521106	MTC-HSK-A100-12-160-C-0-A-AAA1	30522170
	100	12	24	32	160	45	10	M10x1	4,52	2	30302825	30512822	30384306	MTC-HSK-A100-12-160-C-0-A-AAA2	30522172
	100	12	24	32	160	45	10	M10x1	9,9	3	30302825	30279404	30297309	MTC-HSK-A100-12-160-C-0-A-AAA3	30326802
	100	12	24	32	200	45	10	M10x1	1,54	1,5	30253152	30512846	30521106	MTC-HSK-A100-12-200-C-0-A-AAA1	30522174
	100	12	24	32	200	45	10	M10x1	4,52	2	30253152	30512842	30384306	MTC-HSK-A100-12-200-C-0-A-AAA2	30522176
	100	12	24	32	200	45	10	M10x1	9,9	3	30253152	30279405	30297309	MTC-HSK-A100-12-200-C-0-A-AAA3	30326812
	100	14	27	34	120	45	10	M10x1	1,54	1,5	30254306	30512813	30521106	MTC-HSK-A100-14-120-C-0-A-AAA1	30522182
	100	14	27	34	120	45	10	M10x1	4,52	2	30254306	30512808	30384306	MTC-HSK-A100-14-120-C-0-A-AAA2	30522184
	100	14	27	34	120	45	10	M10x1	9,9	3	30254306	30279408	30297309	MTC-HSK-A100-14-120-C-0-A-AAA3	30326795
	100	14	27	34	160	45	10	M10x1	1,54	1,5	30302826	30512827	30521106	MTC-HSK-A100-14-160-C-0-A-AAA1	30522186
	100	14	27	34	160	45	10	M10x1	4,52	2	30302826	30512823	30384306	MTC-HSK-A100-14-160-C-0-A-AAA2	30522188
	100	14	27	34	160	45	10	M10x1	9,9	3	30302826	30279410	30297309	MTC-HSK-A100-14-160-C-0-A-AAA3	30326803
	100	14	27	34	200	45	10	M10x1	1,54	1,5	30303050	30512847	30521106	MTC-HSK-A100-14-200-C-0-A-AAA1	30522190

2-channel system MQL shrink chucks ThermoChuck | For automatic tool change, with axial tool length adjustment
Shank HSK-A in accordance with DIN 69893-1 | Available on request

Variant*	HSK-A	Dimensions						G	A _{IN}	sw	Components			Specification	Order No.
		d ₁	d ₂	d ₃	l ₁	l ₂	l ₃				BDY	LS	CU		
	100	14	27	34	200	45	10	M10x1	4,52	2	30303050	30512843	30384306	MTC-HSK-A100-14-200-C-0-A-AAA2	30522192
	100	14	27	34	200	45	10	M10x1	9,9	3	30303050	30279412	30297309	MTC-HSK-A100-14-200-C-0-A-AAA3	30326813
	100	16	27	34	120	48	10	M12x1	1,54	1,5	30302821	30512814	30521106	MTC-HSK-A100-16-120-C-0-A-AAA1	30522198
	100	16	27	34	120	48	10	M12x1	4,52	2	30302821	30512809	30384306	MTC-HSK-A100-16-120-C-0-A-AAA2	30522200
	100	16	27	34	120	48	10	M12x1	9,9	3	30302821	30279414	30297309	MTC-HSK-A100-16-120-C-0-A-AAA3	30326796
	100	16	27	34	160	48	10	M12x1	1,54	1,5	30302827	30512828	30521106	MTC-HSK-A100-16-160-C-0-A-AAA1	30522202
	100	16	27	34	160	48	10	M12x1	4,52	2	30302827	30512824	30384306	MTC-HSK-A100-16-160-C-0-A-AAA2	30522204
	100	16	27	34	160	48	10	M12x1	9,9	3	30302827	30279416	30297309	MTC-HSK-A100-16-160-C-0-A-AAA3	30326804
	100	16	27	34	200	48	10	M12x1	1,54	1,5	30302831	30512848	30521106	MTC-HSK-A100-16-200-C-0-A-AAA1	30522206
	100	16	27	34	200	48	10	M12x1	4,52	2	30302831	30512844	30384306	MTC-HSK-A100-16-200-C-0-A-AAA2	30522208
	100	16	27	34	200	48	10	M12x1	9,9	3	30302831	30279418	30297309	MTC-HSK-A100-16-200-C-0-A-AAA3	30326814
	100	18	33	42	120	48	10	M12x1	1,54	1,5	30253155	30512815	30521106	MTC-HSK-A100-18-120-C-0-A-AAA1	30522214
	100	18	33	42	120	48	10	M12x1	4,52	2	30253155	30512810	30384306	MTC-HSK-A100-18-120-C-0-A-AAA2	30522216
	100	18	33	42	120	48	10	M12x1	9,9	3	30253155	30279422	30297309	MTC-HSK-A100-18-120-C-0-A-AAA3	30326797
	100	18	33	42	160	48	10	M12x1	1,54	1,5	10096879	30512829	30521106	MTC-HSK-A100-18-160-C-0-A-AAA1	30522218
	100	18	33	42	160	48	10	M12x1	4,52	2	10096879	30512825	30384306	MTC-HSK-A100-18-160-C-0-A-AAA2	30522220
	100	18	33	42	160	48	10	M12x1	9,9	3	10096879	30279423	30297309	MTC-HSK-A100-18-160-C-0-A-AAA3	30326805
	100	18	33	42	200	48	10	M12x1	1,54	1,5	10107134	30512849	30521106	MTC-HSK-A100-18-200-C-0-A-AAA1	30522222
	100	18	33	42	200	48	10	M12x1	4,52	2	10107134	30512845	30384306	MTC-HSK-A100-18-200-C-0-A-AAA2	30522224
	100	18	33	42	200	48	10	M12x1	9,9	3	10107134	30279427	30297309	MTC-HSK-A100-18-200-C-0-A-AAA3	30326815
	100	20	33	42	120	50	10	M16x1	4,52	2	30302822	30512817	30384306	MTC-HSK-A100-20-120-C-0-A-AAA2	30522230
	100	20	33	42	120	50	10	M16x1	9,9	3	30302822	30512816	30297309	MTC-HSK-A100-20-120-C-0-A-AAA3	30522232
	100	20	33	42	120	50	10	M16x1	17,35	4	30302822	30279430	30297310	MTC-HSK-A100-20-120-C-0-A-AAA4	30326798
	100	20	33	42	160	50	10	M16x1	4,52	2	10096880	30512833	30384306	MTC-HSK-A100-20-160-C-0-A-AAA2	30522234
	100	20	33	42	160	50	10	M16x1	9,9	3	10096880	30512830	30297309	MTC-HSK-A100-20-160-C-0-A-AAA3	30522236
	100	20	33	42	160	50	10	M16x1	17,35	4	10096880	30279432	30297310	MTC-HSK-A100-20-160-C-0-A-AAA4	30326806
	100	20	33	42	200	50	10	M16x1	4,52	2	30302832	30512853	30384306	MTC-HSK-A100-20-200-C-0-A-AAA2	30522238
	100	20	33	42	200	50	10	M16x1	9,9	3	30302832	30512850	30297309	MTC-HSK-A100-20-200-C-0-A-AAA3	30522240
	100	20	33	42	200	50	10	M16x1	17,35	4	30302832	30279433	30297310	MTC-HSK-A100-20-200-C-0-A-AAA4	30326816
	100	25	44	53	160	56	10	M16x1	1,54	2	30258455	30512834	30384306	MTC-HSK-A100-25-160-C-0-A-AAA2	30522246
	100	25	44	53	160	56	10	M16x1	4,52	3	30258455	30512831	30297309	MTC-HSK-A100-25-160-C-0-A-AAA3	30522248
	100	25	44	53	160	56	10	M16x1	9,9	4	30258455	30279435	30297310	MTC-HSK-A100-25-160-C-0-A-AAA4	30326807
	100	25	44	53	200	56	10	M16x1	1,54	2	30302833	30512854	30384306	MTC-HSK-A100-25-200-C-0-A-AAA2	30522250
	100	25	44	53	200	56	10	M16x1	4,52	3	30302833	30512851	30297309	MTC-HSK-A100-25-200-C-0-A-AAA3	30522252
	100	25	44	53	200	56	10	M16x1	9,9	4	30302833	30279436	30297310	MTC-HSK-A100-25-200-C-0-A-AAA4	30326817
	100	32	44	53	160	60	10	M16x1	4,52	2	30303048	30512835	30384306	MTC-HSK-A100-32-160-C-0-A-AAA2	30522258
	100	32	44	53	160	60	10	M16x1	9,9	3	30303048	30512832	30297309	MTC-HSK-A100-32-160-C-0-A-AAA3	30522260
	100	32	44	53	160	60	10	M16x1	17,35	4	30303048	30279442	30297310	MTC-HSK-A100-32-160-C-0-A-AAA4	30326808
	100	32	44	53	200	60	10	M16x1	4,52	2	30302834	30512856	30384306	MTC-HSK-A100-32-200-C-0-A-AAA2	30522262
	100	32	44	53	200	60	10	M16x1	9,9	3	30302834	30512852	30297309	MTC-HSK-A100-32-200-C-0-A-AAA3	30522264
	100	32	44	53	200	60	10	M16x1	17,35	4	30302834	30279443	30297310	MTC-HSK-A100-32-200-C-0-A-AAA4	30326818

* The exact determination of the variant can be found in the selection system 2-channel system chucks.
The preferred series is marked with a green .

Dimensions in mm.
Items included: Tool body, length adjustment screw and coolant unit as assembly.
These components can also be ordered separately. (see table)
Design: Permissible run-out deviation on the hollow taper shank in relation to the clamping diameter d₁ = 3 µm. The clamping diameter is designed for a shank tolerance of h6.

Different versions with chip available on request.
Balancing value: G 2.5 at 25,000 min⁻¹ as delivered.



Discover tool and service solutions now that give you a lead:

BORE MACHINING

REAMING | FINE BORING

DRILLING FROM SOLID | BORING | COUNTERSINKING

MILLING

CLAMPING

TURNING

ACTUATING

SETTING | MEASURING | DISPENSING

SERVICES

FOLLOW US

